

YAMAHA NETWORK BOARD RCX series

DeviceNet

User's Manual

ENGLISH 

YAMAHA MOTOR CO., LTD.

IM Operations

882 Soude, Naka-ku, Hamamatsu, Shizuoka 435-0054.Japan
URL <http://www.yamaha-motor.jp/robot/index.html>

E79-Ver. 2.04

Introduction

Thank you for purchasing the DeviceNet compatible module. This DeviceNet compatible module is an option module that allows the YAMAHA robot controller RCX series to be connected as a DeviceNet system slave module.

The robot controller explained in this manual refers to the RCX series. This manual describes the flow of operations from wiring the DeviceNet compatible module to programming, and includes setting examples.

Refer to the respective product manuals for details on other devices such as connecting the master module and sequence programming.

Refer to the controller user's manual and programming manual supplied with the YAMAHA robot controller for details on operating the robot controller and on the robot program.

Applicable controllers: RCX240, RCX141, RCX142, RCX40, RCX221 and RCX222

Model names as used in this manual include the following controllers.

RCX240:	Includes RCX240, RCX141, RCX142 and RCX40 (4-axis controllers)
RCX14x:	Includes RCX141, RCX142 and RCX40 (4-axis controllers excluding RCX240)*
RCX22x:	Includes RCX221 and RCX222 (2-axis controllers)

* Here, "RCX14x" does not include RCX240 and is used when there is a difference between the RCX240 and other 4-axis controllers due to differences in software versions.

● NOTE

The master module explained in this manual is based on the OMRON CJ1 series. If the explanations differ from other brands, refer to the manual for the product being used.

Safety Precautions (Always read before starting use)

Always read this manual, the robot controller user's manual and programming manual before using this product. Take special care to safety, and correctly handle the product. The cautions given in this manual are related to this product. Refer to the robot controller user's manual for details on the cautions to be taken with the robot controller system using this product.

* The safety precautions are ranked as "WARNING" and "CAUTION" in this manual.



WARNING

FAILURE TO FOLLOW WARNING INSTRUCTIONS COULD RESULT IN SERIOUS INJURY OR DEATH TO THE OPERATOR OR PERSON SERVICING THE PRODUCT.



CAUTION

Failure to follow CAUTION instructions may result in injury to the operator or person servicing product, or damage to the product or peripheral equipment.



NOTE

Explains the key point in the operation in a simple and clear manner.

Note that some items described as "CAUTION" may lead to serious results depending on the situation. In any case, important information that must be observed is explained. Store this manual where it can be easily referred to, and make sure that it is delivered to the end user.

DeviceNet is a registered trademark of ODVA (Open DeviceNet Vendor Association).

[Precautions for design]

**WARNING**

- REFER TO THE DEVICENET SYSTEM MASTER MODULE USER'S MANUAL AND THIS MANUAL FOR DETAILS ON THE STATE OF THE DEVICENET SYSTEM AND ROBOT CONTROLLER WHEN A COMMUNICATION ERROR OCCURS WITH THE DEVICENET SYSTEM, ETC. CONFIGURE AN INTERLOCK CIRCUIT IN THE SEQUENCE PROGRAM SO THAT THE SYSTEM, INCLUDING THE ROBOT CONTROLLER WILL WORK SAFELY USING THE COMMUNICATION STATUS INFORMATION.
- THE SAFETY CONNECTOR OF THE ROBOT CONTROLLER HAS AN EMERGENCY STOP TERMINAL TO TRIGGER EMERGENCY STOP. USING THIS TERMINAL, PREPARE A PHYSICAL INTERLOCK CIRCUIT SO THAT THE SYSTEM INCLUDING THE ROBOT CONTROLLER WILL WORK SAFETY.

**CAUTION**

- The control line and communication cable must not be bound with or placed near the main circuit or power line. Separate these by at least 100mm. Failure to observe this could lead to malfunctions caused by noise.
- The dedicated input of STD.DIO connector provided on the RCX240 controllers will be disabled except for an interlock signal (DI 11). When the Board condition (external 24V monitor control) of system parameters is set invalid, the interlock signal (DI 11) will also be disabled. On the RCX22x, the dedicated input of STD. DIO connector will be disabled, but the interlock signal (DI 11) in SAFETY connector enabled.

[Precautions for installation]

**WARNING**

- ALWAYS CRIMP, PRESS-FIT OR SOLDER THE CONNECTOR WIRE CONNECTIONS WITH THE MAKER-DESIGNATED TOOL, AND SECURELY CONNECT THE CONNECTOR TO THE MODULE.
- ALWAYS SHUT OFF ALL PHASES OF THE POWER SUPPLY EXTERNALLY BEFORE STARTING INSTALLATION OR WIRING WORK.
FAILURE TO SHUT OFF ALL PHASES COULD LEAD TO ELECTRIC SHOCKS OR PRODUCT DAMAGE.

**CAUTION**

- Use the robot controller within the environment specifications given in the manual. Use in an environment outside the environment specification range could lead to electric shocks, fires, malfunctioning, product damage or deterioration.
- Install the DeviceNet compatible module into the robot controller, and securely fix with screws.
- Never directly touch the conductive sections or electronic parts other than the rotary switch on the DeviceNet compatible module.
- Never directly touch the conductive sections or electric parts inside the controller.
- Accurately connect each connection cable connector to the mounting section. Failure to observe this could lead to malfunctions caused by a connection fault.

[Precautions for wiring]**WARNING**

-
- ALWAYS SHUT OFF ALL PHASES OF THE POWER SUPPLY EXTERNALLY BEFORE STARTING INSTALLATION OR WIRING WORK. FAILURE TO SHUT OFF ALL PHASES COULD LEAD TO ELECTRIC SHOCKS OR PRODUCT DAMAGE.
 - ALWAYS INSTALL THE TERMINAL COVERS ENCLOSED WITH THE PRODUCT BEFORE TURNING ON THE POWER OR OPERATING THE PRODUCT AFTER INSTALLATION OR WIRING WORK. FAILURE TO INSTALL THE TERMINAL COVER COULD LEAD TO MALFUNCTIONS.
-

**CAUTION**

-
- Tighten the terminal screws within the specified torque range. A loose terminal screw could lead to short-circuiting or malfunctioning. If the terminal screw is too tight, short-circuiting or malfunctioning could occur due to screw damage.
 - Make sure that foreign matter, such as cutting chips or wire scraps, do not enter the robot controller.
 - The communication cables connected to the DeviceNet compatible module must be placed in a conduit or fixed with a clamp. If the cable is not placed in a conduit or fixed with a clamp, the module or cable could be damaged by the cable shifting, movement or unintentional pulling leading to malfunctioning caused by an improper cable connection.
 - Do not disconnect the communication cable connected to the DeviceNet compatible module by pulling on the cable section. Loosen the screws on the connector, and then disconnect the cable. Pulling on the cable fixed with screws could lead to module or cable damage, or malfunctioning caused by an improper cable connection.
-

[Precautions for starting and maintenance]**WARNING**

-
-
- DO NOT TOUCH THE TERMINALS WHILE THE POWER IS ON. FAILURE TO OBSERVE THIS COULD LEAD TO MALFUNCTIONING.
 - ALWAYS SHUT OFF ALL PHASES OF THE POWER SUPPLY EXTERNALLY BEFORE CLEANING OR TIGHTENING THE TERMINAL SCREWS. FAILURE TO SHUT OFF ALL PHASES COULD LEAD TO ELECTRIC SHOCKS, PRODUCT DAMAGE OR MALFUNCTIONING. A LOOSE SCREW COULD LEAD TO DROPPING, SHORT-CIRCUITING OR MALFUNCTIONING. IF THE SCREW IS TOO TIGHT, SHORT-CIRCUITING OR MALFUNCTIONING COULD OCCUR DUE TO SCREW DAMAGE.
 - NEVER DISASSEMBLE OR MODIFY ANY OF THE ROBOT CONTROLLER MODULES. FAILURE TO OBSERVE THIS COULD LEAD TO TROUBLE, MALFUNCTIONING, INJURIES OR FIRES.
 - ALWAYS SHUT OFF ALL PHASES OF THE POWER SUPPLY EXTERNALLY BEFORE INSTALLING OR REMOVING THE DEVICENET COMPATIBLE MODULE. FAILURE TO SHUT OFF ALL PHASES COULD LEAD TO ROBOT CONTROLLER TROUBLE OR MALFUNCTIONING.
 - WHEN USING THE ROBOT CONTROLLER WITH THE DEVICENET COMPATIBLE MODULE MOUNTED, ALWAYS MOUNT THE ENCLOSED FERRITE CORE FOR NOISE MEASURES ON THE POWER CABLE AS CLOSE TO THE ROBOT CONTROLLER AS POSSIBLE. FAILURE TO MOUNT THIS FERRITE CORE COULD LEAD TO MALFUNCTIONING CAUSED BY NOISE.
-
-

**CAUTION**

The DeviceNet system may not function properly if the master module and robot controller power are turned ON simultaneously. Always turn the robot controller power ON after turning ON the power for the master module ON.

[Precautions for disposal]**CAUTION**

Dispose of this product as industrial waste.

This manual does not guarantee the implementation of industrial rights or other rights, and does not authorize the implementation rights. YAMAHA shall not be held liable for any problems regarding industrial rights that occur through the use of the contents given in this manual.

2011 YAMAHA MOTOR CO., LTD.

Warranty

For information on the product warranty, please contact your local agent where you purchased your product.

General Contents

Chapter 1 OUTLINE		
1. Features		1-1
2. Mechanism		1-2
3. Names of each part on the DeviceNet compatible module		1-3
4. Assignment of DeviceNet compatible I/O		1-4
5. Shift of DeviceNet system connection status and robot controller status		1-7
Chapter 2 CONNECTION		
1. Confirming the DeviceNet compatible module settings		2-1
2. Setting to the DeviceNet system specification controller		2-2
2.1 Saving the robot controller data		2-2
2.2 Installing the DeviceNet compatible module		2-2
2.3 Response when starting the robot controller		2-2
3. Setting the DeviceNet compatible module		2-3
3.1 Setting the MAC ID		2-3
3.2 Setting the communication speed		2-4
4. Noise measures		2-6
4.1 Mounting the ferrite core		2-6
5. Connecting to the DeviceNet system		2-7
5.1 Connecting to the cable terminal to the controller		2-7
5.2 Testing the line from the master module		2-8
6. Parameter setting for DeviceNet serial I/O board		2-9
6.1 Parameter setting for DeviceNet serial I/O board		2-10
Chapter 3 COMMUNICATION		
1. State when robot controller power is turned ON		3-1
2. Communication with master module		3-3
2.1 Receiving data		3-3
2.2 Transmitting data		3-5
3. Direct connection by emulated serialization on parallel DIO		3-8
3.1 Emulated serialization setting on parallel DIO		3-8

4. Referring to communication data 3-11

4.1 Referring to the data from the programming box 3-11

Chapter 4 TROUBLESHOOTING**1. Items to confirm before starting up DeviceNet system 4-1****2. Meanings of LEDs on DeviceNet compatible module 4-2****3. Troubleshooting 4-3**

3.1 Robot controller front panel LED confirmation 4-3

3.2 Programming box error display confirmation 4-4

3.3 DeviceNet compatible module LED confirmation 4-5

3.4 Confirmation from master module 4-5

4. Error messages relating to DeviceNet 4-6**Chapter 5 SPECIFICATIONS****1. Profile 5-1**

1.1 When IO size is set to "Large" 5-1

1.2 When IO size is set to "Small" 5-4

2. Details of input/output signals 5-5**3. Dedicated input/output signal timing chart 5-11**

3.1 Servo ON and emergency stop 5-11

3.2 AUTO mode changeover, program reset and program execution 5-12

3.3 Stopping with program interlock 5-14

4. Sample program 5-16**5. DeviceNet compatible module specifications 5-27****6. DeviceNet specifications 5-28****Chapter 6 APPENDIX****1. Term definition 6-1****2. EDS files 6-2**

Contents

1. Features	1-1
2. Mechanism	1-2
3. Names of each part on the DeviceNet compatible module	1-3
4. Assignment of DeviceNet compatible I/O	1-4
5. Shift of DeviceNet system connection status and robot controller status	1-7

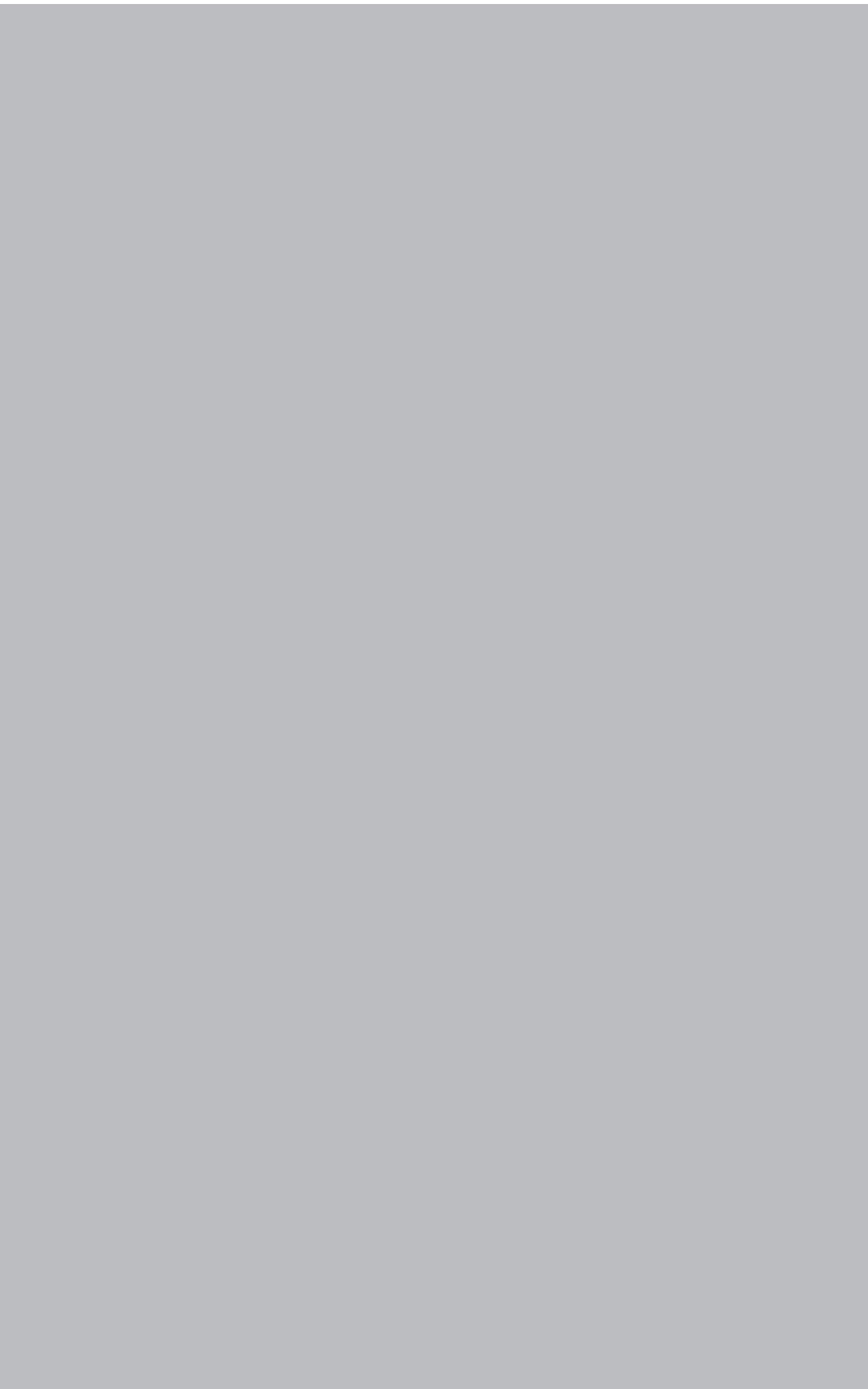

1. Features

The DeviceNet system is a system used to connect the robot controller or scattered input/output modules, etc., with dedicated cables, and to control these modules from the master module.

The DeviceNet system allows wiring to be reduced.

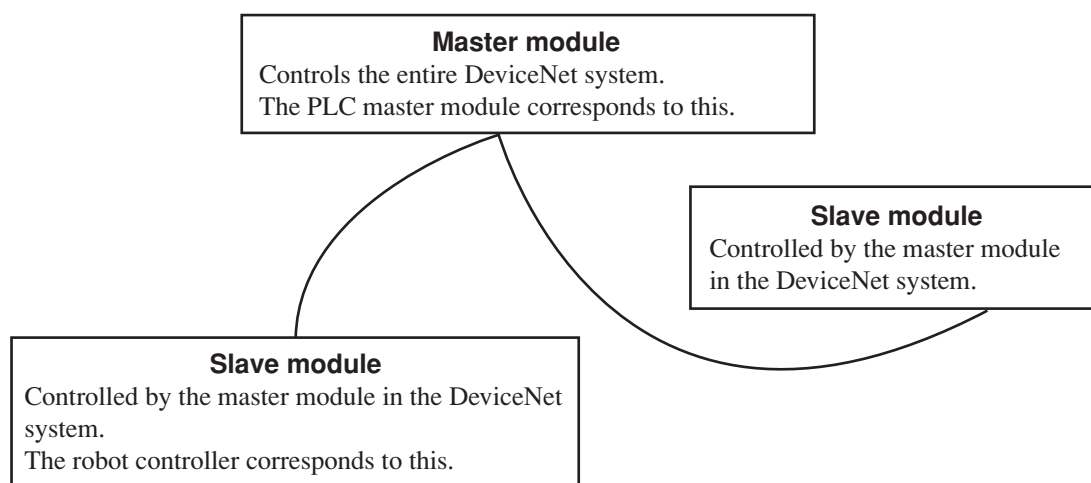

DeviceNet is a registered trademark of ODVA (Open DeviceNet Vendor Association).



NOTE

The dedicated input of STD.DIO connector provided on the RCX240 controllers will be disabled except for an interlock signal (DI 11). When the Board condition (external 24V monitor control) of system parameters is set invalid, the interlock signal (DI 11) will also be disabled. On the RCX22x, the dedicated input of STD.DIO connector will be disabled, but the interlock signal (DI 11) in SAFETY connector enabled.

[Wiring saving]

One dedicated cable (5-wire) is used to connect the robot controller and PLC. This allows the entire system wiring to be reduced.

[Emulated serialization on parallel DIO]

By making the robot controller's internal settings without using a robot program, the various I/O devices, such as the sensors and relays mounted on the robot controller's parallel I/O can be controlled from the PLC as if they were DeviceNet system I/O devices.



CAUTION

An emergency stop terminal for hardwire is provided in SAFETY connector on the robot controller.

In the case of the RCX240, when the DeviceNet system is used while STD. DIO is not used (external DC 24V power supply is not used), the Board condition (external 24V monitor control) of system parameters must be set invalid. If it is left valid, the STD. DIO interlock signal is enabled causing an error in the robot operation commands.

2. Mechanism

The mechanism of communication is explained in this section to provide an understanding of how the robot controller and master module operate via the DeviceNet system.

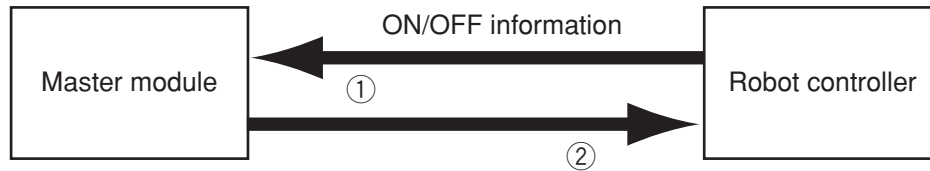

- ① The robot controller's ON/OFF information is sent to the master module via the network (DeviceNet system cable).
- ② The master module's ON/OFF information is sent to the robot controller via the network (DeviceNet system cable).

- * **The robot controller monitors the ON/OFF information at a 10ms cycle.**
- * **The ON/OFF information consists of two words each of dedicated I/O words, 14 words each of general-purpose I/O words as word information, and 16 points each of dedicated I/O points, 96 points each of general-purpose I/O points as bit information. However, when the number of channels that the DeviceNet compatible module occupies is set to "Small" (2CH each of I/O) by option board parameter, bit information consists 16 points each of dedicated I/O points and 16 points each of general-purpose I/O points, so that word information cannot be handled.**



NOTE

The number of channels that the DeviceNet compatible module occupies can be set to either "Large" (24CH each of I/O) or "Small" (2CH each of I/O) by option board parameter. This function is only supported by Ver. 8.63 onwards of the RCX14x controllers and Ver. 9.09 onwards of the RCX22x controllers.

If the following is executed with the robot program in the robot controller, the bit information will be sent to the master module via the DeviceNet system by ①.

SO (20)=1

Conversely, if the following is executed with the robot program, the bit information received from the master module via the DeviceNet system will be monitored by ②, and the robot controller will wait for the ON information.

WAIT SI (20)=1

If the following is executed with the robot program in the robot controller, the word information will be sent to the master module via the DeviceNet system by ①.

SOW (2)= 256

Conversely, if the following is executed with the robot program, the word information received from the master module via the DeviceNet system will be substituted in integer variable A% by ②.

A% = SIW (3)

3. Names of each part on the DeviceNet compatible module

The part names of the DeviceNet compatible module installed in the robot controller are described in this section. The DeviceNet compatible module is installed into an optional slot in the robot controller.

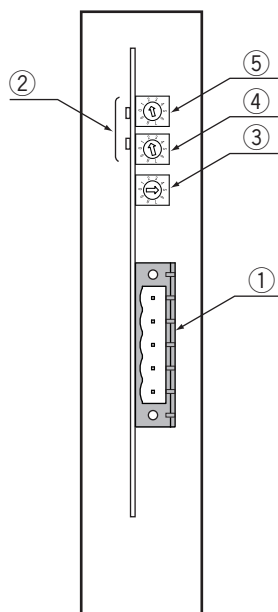

Front of the unit

① **DeviceNet system cable terminals**

These terminals are used to connect the DeviceNet system cable. Each of the five terminals has a meaning, so do not make miswiring. These terminals are "V-" (Black), "CAN L" (Blue), "SHIELD (-)", "CAN H" (White) and "V+" (Red) from the top.

② **Transmission monitor LED**

The status in the DeviceNet system is indicated with ON, OFF and flickering status of two LEDs. These terminals are "MS" and "NS" from the top.

③ **MAC ID setting switch (LSB: 1st digit)**

This is the rotary switch for setting the robot controller MAC ID in the DeviceNet system. The 1st digit of the MAC ID is set with this switch.

④ **MAC ID setting switch (MSB: 2nd digit)**

This is the rotary switch for setting the robot controller MAC ID in the DeviceNet system. The 2nd digit of the MAC ID is set with this switch.

⑤ **Communication speed switch (BPS)**

This is the rotary switch for setting the DeviceNet system's communication speed.

4. Assignment of DeviceNet compatible I/O

The table below shows the correspondence of the robot controller's serial I/O to the I/O data (channel) on the DeviceNet. The number of channels assigned to the DeviceNet compatible module can be set to either 24 channels each or 2 channels each of I/O by robot controller parameter.

■ Using Input 24CH / Output 24CH

Serial output (Robot controller → Master module)			Serial input (Master module → Robot controller)		
Robot controller		Master module	Robot controller		Master module
Port No.		Channel No.	Port No.		Channel No.
	SOW(0) ^{*1}	(mCH)		SIW(0) ^{*1}	(nCH)
	SOW(1) ^{*1}	(m+1CH)		SIW(1) ^{*1}	(n+1CH)
SOD(2)	SOW(2)	(m+2CH)	SID(2)	SIW(2)	(n+2CH)
	SOW(3)	(m+3CH)		SIW(3)	(n+3CH)
SOD(4)	SOW(4)	(m+4CH)	SID(4)	SIW(4)	(n+4CH)
	SOW(5)	(m+5CH)		SIW(5)	(n+5CH)
SOD(6)	SOW(6)	(m+6CH)	SID(6)	SIW(6)	(n+6CH)
	SOW(7)	(m+7CH)		SIW(7)	(n+7CH)
SOD(8)	SOW(8)	(m+8CH)	SID(8)	SIW(8)	(n+8CH)
	SOW(9)	(m+9CH)		SIW(9)	(n+9CH)
SOD(10)	SOW(10)	(m+10CH)	SID(10)	SIW(10)	(n+10CH)
	SOW(11)	(m+11CH)		SIW(11)	(n+11CH)
SOD(12)	SOW(12)	(m+12CH)	SID(12)	SIW(12)	(n+12CH)
	SOW(13)	(m+13CH)		SIW(13)	(n+13CH)
SOD(14)	SOW(14)	(m+14CH)	SID(14)	SIW(14)	(n+14CH)
	SOW(15)	(m+15CH)		SIW(15)	(n+15CH)
SO0(7 to 0) ^{*2}	(m+16CH)	7 to 0	SI0(7 to 0) ^{*2}	(n+16CH)	7 to 0
SO1(7 to 0) ^{*2}		15 to 8	SI1(7 to 0) ^{*2}		15 to 8
SO2(7 to 0)	(m+17CH)	7 to 0	SI2(7 to 0)	(n+17CH)	7 to 0
SO3(7 to 0)		15 to 8	SI3(7 to 0)		15 to 8
SO4(7 to 0)	(m+18CH)	7 to 0	SI4(7 to 0)	(n+18CH)	7 to 0
SO5(7 to 0)		15 to 8	SI5(7 to 0)		15 to 8
SO6(7 to 0)	(m+19CH)	7 to 0	SI6(7 to 0)	(n+19CH)	7 to 0
SO7(7 to 0)		15 to 8	SI7(7 to 0)		15 to 8
SO10(7 to 0)	(m+20CH)	7 to 0	SI10(7 to 0)	(n+20CH)	7 to 0
SO11(7 to 0)		15 to 8	SI11(7 to 0)		15 to 8
SO12(7 to 0)	(m+21CH)	7 to 0	SI12(7 to 0)	(n+21CH)	7 to 0
SO13(7 to 0)		15 to 8	SI13(7 to 0)		15 to 8
SO14(7 to 0)	(m+22CH)	7 to 0	SI14(7 to 0)	(n+22CH)	7 to 0
SO15(7 to 0)		15 to 8	SI15(7 to 0)		15 to 8
Reserved ^{*3}	(m+23CH)	15 to 0	Reserved ^{*3}	(n+23CH)	15 to 0

m : Input-area head CH number assigned to master module
n : Output-area head CH number assigned to master module

Note)

*1: These are used as a dedicated command and so cannot be used as general-purpose I/O data.

*2: These are used as a dedicated I/O and so cannot be used as general-purpose I/O data.

*3: Reserved area.

■ Using Input 2CH / Output 2CH

Serial output (Robot controller → Master module)		Serial input (Master module → Robot controller)	
Robot controller	Master module	Robot controller	Master module
Port No.	Channel No.	Port No.	Channel No.
SO0(7 to 0) ^{**1}	(mCH)	SI0(7 to 0) ^{**1}	(nCH)
SO1(7 to 0) ^{**1}		SI1(7 to 0) ^{**1}	
SO2(7 to 0)	(m+1CH)	SI2(7 to 0)	(n+1CH)
SO3(7 to 0)		SI3(7 to 0)	

m : Input-area head CH number assigned to master module
n : Output-area head CH number assigned to master module

Note)

*1: These are used as a dedicated I/O and so cannot be used as general-purpose I/O data.



CAUTION

The number of channels assigned to the DeviceNet compatible module can be selected when an RCX14x controller of Ver. 8.63 onwards or an RCX22x controller of Ver. 9.09 onwards is used. Earlier version controllers support only input 24CH and output 24CH.



NOTE

- Each channel consists of 16-bit data.
- SOn() and SIn() are handled as unsigned 8-bit integer data.
- SOW(n) and SIW(n) are handled as unsigned 16-bit integer data.
- SOD(n) and SID(n) are handled as signed 32-bit integer data.
- The upper and lower words of SOD(n) respectively correspond to SOW(n+1) and SOW(n).
- The upper and lower words of SID(n) respectively correspond to SIW(n+1) and SIW(n).
- The dedicated input of STD.DIO connector provided on the RCX240 controllers will be disabled except for an interlock signal (DI 11). When the Board condition (external 24V monitor control) of system parameters is set invalid, the interlock signal (DI 11) will also be disabled. On the RCX22x, the dedicated input of STD.DIO connector will be disabled, but the interlock signal (DI 11) in SAFETY connector enabled.

4. Assignment of DeviceNet compatible I/O

The head channel numbers in the input and output areas differ depending on the method of assigning the DeviceNet compatible module to the master module and the MAC ID setting. Refer to the master module and PLC instruction manuals for details.

Example: When fixed assignment is applied to fixed assignment area 1 while using a programmable controller (OMRON CJ1G-CPU42H) and a DeviceNet unit (OMRON CJ1W-DRM21).

Output-area CH (n) = 3200 + MAC ID

Input-area head CH (m) = 3300 + MAC ID

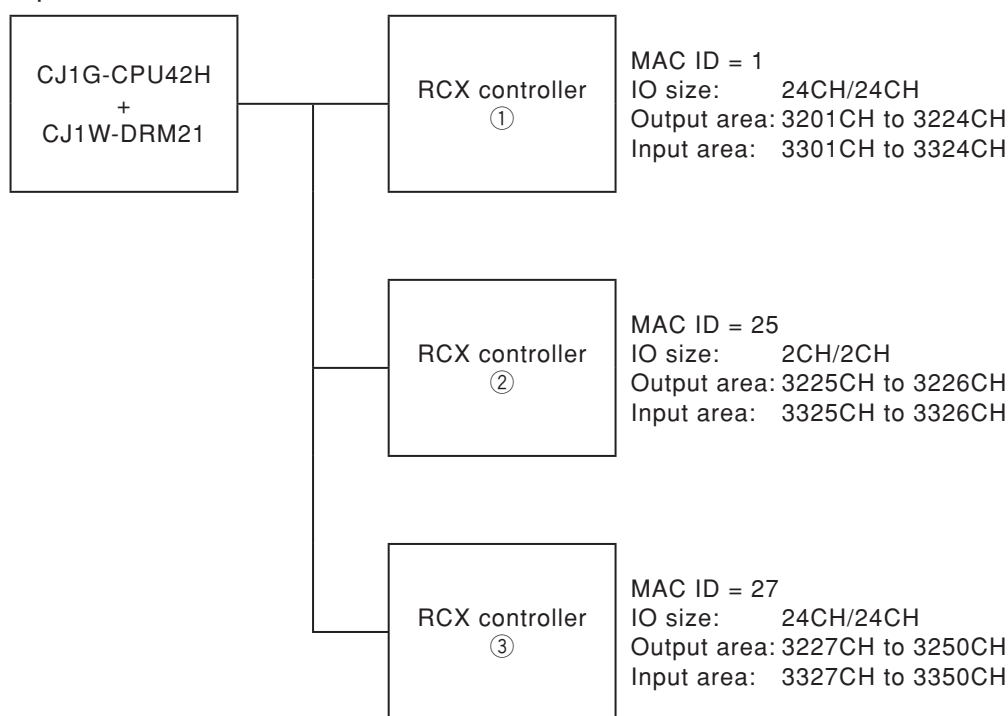

Master module	Controller		
Channel No.	MAC ID	Number of channels	Data
3201 to 3224	1	24	RCX controller ① serial input
3225 to 3226	25	2	RCX controller ② serial input
3227 to 3250	27	24	RCX controller ③ serial input
⋮			
3301 to 3324	1	24	RCX controller ① serial output
3325 to 3326	25	2	RCX controller ② serial output
3327 to 3350	27	24	RCX controller ③ serial output
⋮			

5. Shift of DeviceNet system connection status and robot controller status

Always start the DeviceNet system specification robot controller in the servo OFF state after the power is turned ON.

① Normal state of DeviceNet system connection when robot controller power is turned ON

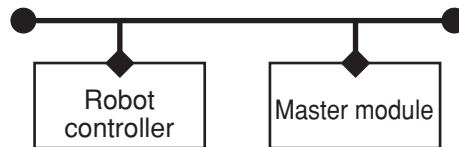

- Emergency stop/interlock signals in DeviceNet system are valid.
- When SAFE mode is enabled, service mode input signal is made valid with SI (02) in the DeviceNet system.
- Emergency stop terminal in SAFETY connector is valid.
- Interlock signal in STD. DIO connector is valid unless the Board condition (external 24V monitor control) of system parameters is set invalid. (RCX240)
- Interlock signal in SAFETY connector is valid. (RCX22x)
- When the Board condition (external 24V monitor control) of system parameters is left valid while SAFE mode is enabled, service mode input signal is made valid with DI (02) in SAFETY connector. (RCX240)
- When SAFE mode is enabled, service mode input signal is made valid with DI (02) in SAFETY connector. (RCX22x)

* The signals in the DeviceNet system are sent and received.

② Shift from DeviceNet system normal connection state to DeviceNet system erroneous connection state

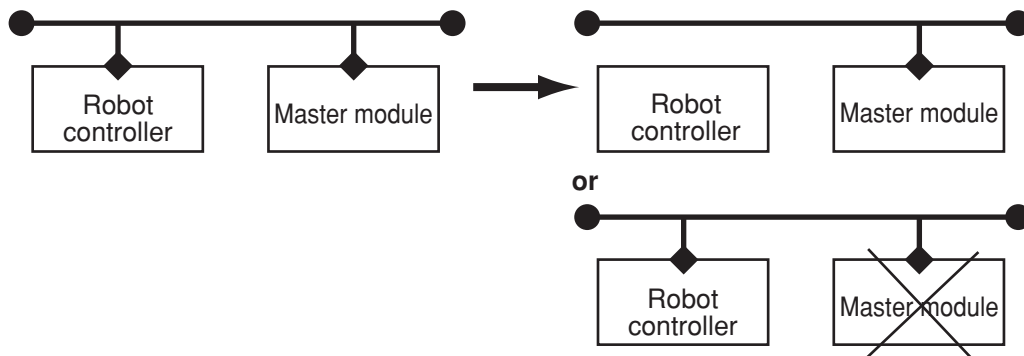

- Emergency stop input turns off with SI (00) in the robot controller.
- Service mode input turns off with SI (02) in the robot controller.
- Emergency stop terminal in SAFETY connector is valid.
- Interlock signal in STD. DIO connector is valid when the Board condition (external 24V monitor control) of system parameters is left valid. (RCX240)

- Interlock signal in SAFETY connector is valid. (RCX22x)
- When the Board condition (external 24V monitor control) of system parameters is left valid while SAFE mode is enabled, service mode input signal is made valid with DI (02) in SAFETY connector. (RCX240)
- When SAFE mode is enabled, service mode input signal is made valid with DI (02) in SAFETY connector. (RCX22x)
- * The signals in the DeviceNet system are not sent or received.
- * The "DeviceNet Link Error" is added to the error history in the robot controller.
- * If the connection to the DeviceNet system shifts from the normal state to the erroneous state, the DeviceNet system connection must be returned to the normal state.
- * The DeviceNet system will return when the DeviceNet system connection is recovered to the normal state.

③ **DeviceNet system erroneous connection state due to following factors when robot controller power is turned ON**

- Connection to DeviceNet system not possible
- Error in master module

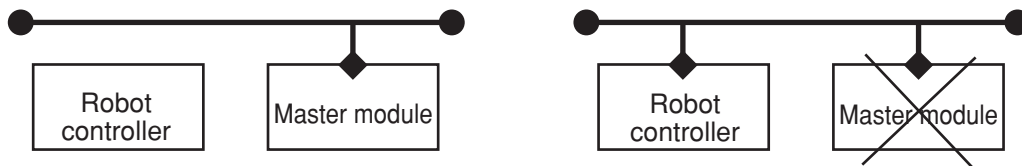

- Emergency stop/interlock signals in DeviceNet system are invalid.
- When SAFE mode is enabled, service mode input signal is made valid with SI (02) in the DeviceNet system.
- Emergency stop terminal in SAFETY connector is valid.
- Interlock signal in STD. DIO connector is valid when the Board condition (external 24V monitor control) of system parameters is left valid. (RCX240)
- Interlock signal in SAFETY connector is valid. (RCX22x)
- When the Board condition (external 24V monitor control) of system parameters is left valid while SAFE mode is enabled, service mode input signal is made valid with DI (02) in SAFETY connector. (RCX240)
- When SAFE mode is enabled, service mode input signal is made valid with DI (02) in SAFETY connector. (RCX22x)
- * The signals on the DeviceNet system cannot be exchanged.
- * The "DeviceNet Link Error" has been added to the error history in the robot controller.
(A standby state for up to 10 seconds will occur to check the communication.)

- * As opposed to the state given in ②, in this state, the emergency stop state by SI (00) is not attained in the controller, so the robot can be operated from the programming box.
(The robot controller can be started independently when setting up the system, etc.)
- * Service mode input signal cannot be invalidated with SI (02) when SAFE mode is enabled, so change the service mode parameter setting in SYSTEM > PARAM mode. In this case, take full precautions to prevent improper settings that might lead to a hazardous situation.
- * When the connection to the DeviceNet system is correctly recovered, the system will automatically return to the DeviceNet system.

④ **Transmission from DeviceNet system erroneous connection state to DeviceNet correct connection state when robot controller power is turned ON**

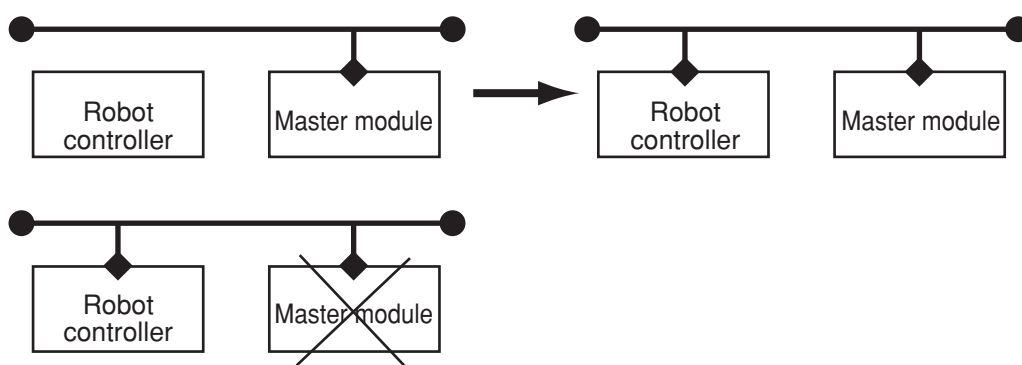

- DeviceNet system emergency stop/interlock signals change to valid state.
 - Emergency stop terminal in SAFETY connector is valid.
 - Interlock signal in STD. DIO connector is valid when the Board condition (external 24V monitor control) of system parameters is left valid. (RCX240)
 - Interlock signal in SAFETY connector is valid. (RCX22x)
 - When the Board condition (external 24V monitor control) of system parameters is left valid while SAFE mode is enabled, service mode input signal is made valid with DI (02) in SAFETY connector. (RCX240)
 - When SAFE mode is enabled, service mode input signal is made valid with DI (02) in SAFETY connector. (RCX22x)
- * The signals in the DeviceNet system can be sent and received.
 - * When service mode parameter setting in SYSTEM > PARAM mode has been changed while SAFE mode is enabled, make the service mode parameter setting again. In this case, take full precautions to prevent improper settings that might lead to a hazardous situation.
 - * The DeviceNet system will return when the DeviceNet system connection is recovered to the normal state.

MEMO

Contents

1.	Confirming the DeviceNet compatible module settings	2-1
2.	Setting to the DeviceNet system specification controller	2-2
2.1	Saving the robot controller data	2-2
2.2	Installing the DeviceNet compatible module	2-2
2.3	Response when starting the robot controller	2-2
3.	Setting the DeviceNet compatible module	2-3
3.1	Setting the MAC ID	2-3
3.2	Setting the communication speed	2-4
4.	Noise measures	2-6
4.1	Mounting the ferrite core	2-6
5.	Connecting to the DeviceNet system	2-7
5.1	Connecting to the cable terminal to the controller	2-7
5.2	Testing the line from the master module	2-8
6.	Parameter setting for DeviceNet serial I/O board	2-9
6.1	Parameter setting for DeviceNet serial I/O board	2-10

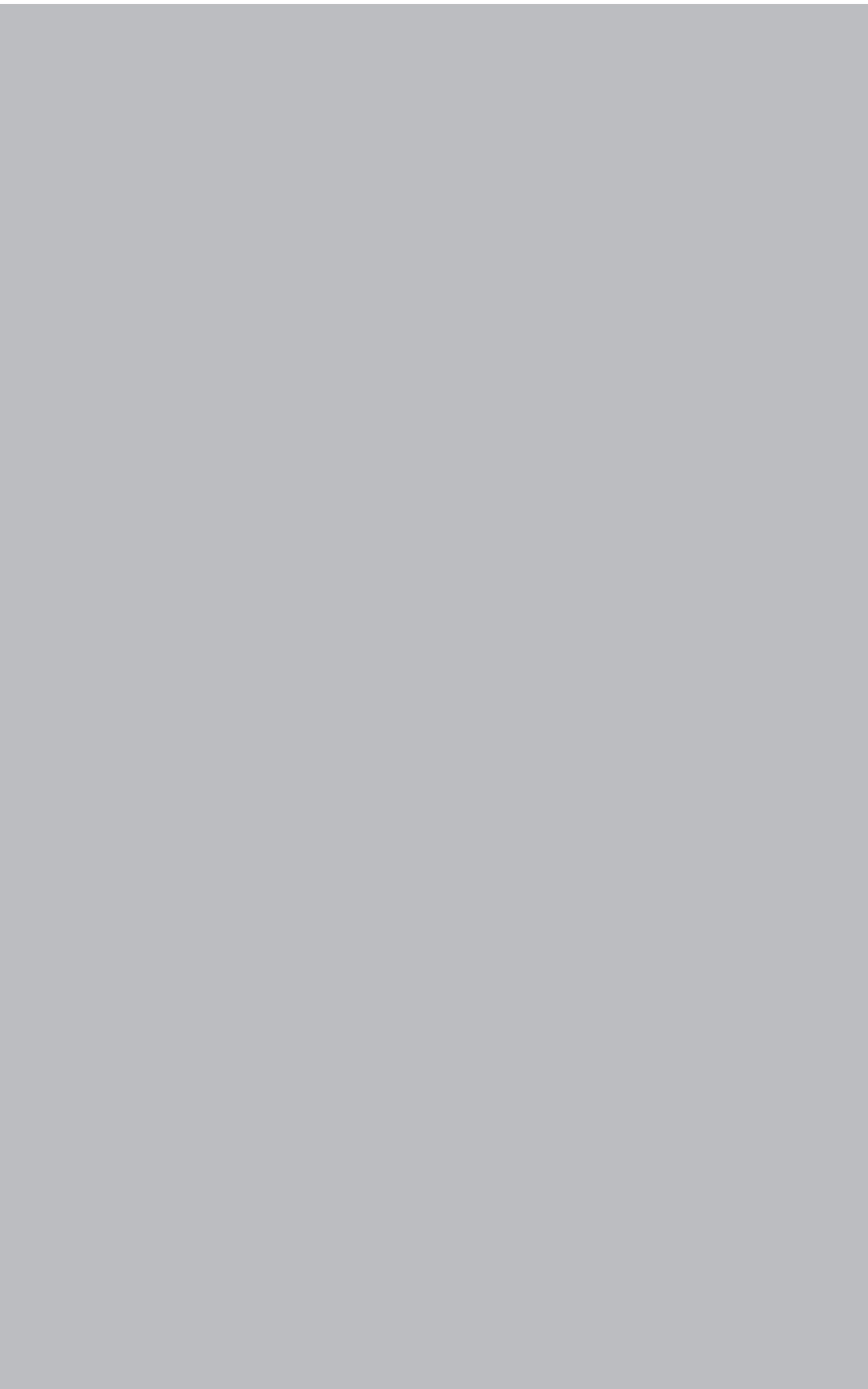

1. Confirming the DeviceNet compatible module settings

When using the DeviceNet system specification robot controller, the DeviceNet compatible module's MAC ID and communication speed setting can be confirmed from a programming box (RPB for RCX22x and RCX240 or MPB for RCX14x; hereafter called "MPB/RPB").

- **When connecting DeviceNet compatible module to existing robot controller**
→ Follow the procedures given in section 2., and change the settings for the DeviceNet system specifications.
- **For DeviceNet system specification robot controller
(When robot controller is purchased with DeviceNet compatible module mounted)**
→ Follow the procedures given in section 3., and set the MAC ID and communication speed.

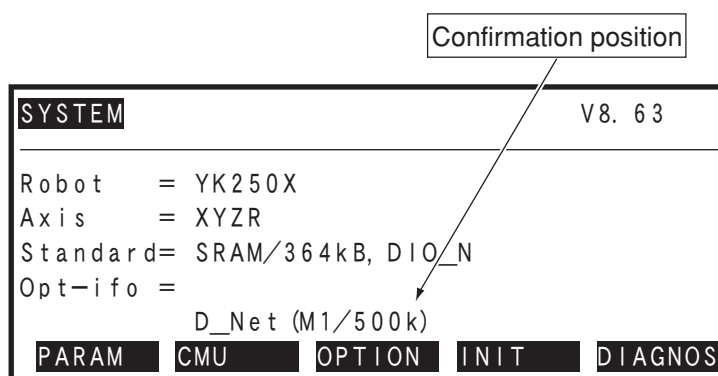

[Operation]

- 1) Press the **MODE** key on the MPB/RPB.
- 2) Press the **F 4** (SYSTEM) key on the MPB/RPB.
- 3) The display above will appear. The MAC ID and communication speed set for the DeviceNet system will appear in the parentheses following "D_Net" on the screen. The meaning of the above example is shown below.

- M1** : MAC ID 1
(Setting range: 0 to 63)
- 500K** : 500Kbps
(Setting speed [unit: bps]: 125K, 250K, 500K)
- * The communication speed must match the master module.



CAUTION

If the robot controller is not connected to the DeviceNet system or if there is an error in the DeviceNet system, the error "DeviceNet Link Error" will appear on the MPB/RPB when the robot controller power is turned ON. The above settings can be confirmed even in this state.

2. Setting to the DeviceNet system specification controller

When connecting the DeviceNet compatible module to an existing robot controller, the DeviceNet compatible module must be installed in the robot controller. Check the DeviceNet system specifications with the procedure given in section 1.

2.1 Saving the robot controller data

Before installing the DeviceNet compatible module into the robot controller, be sure to save the data stored in the robot controller into an external memory by using VIP software, etc.

2.2 Installing the DeviceNet compatible module

Install the DeviceNet compatible module into the robot controller.

At this point, set the MAC ID and communication speed for the DeviceNet compatible module by referring to the procedures given in "3. Setting the DeviceNet compatible module" in chapter 2.

2.3 Response when starting the robot controller

The robot controller will always start up with an "option board setting error" after the DeviceNet compatible module has been installed. Make the following settings as explained below.

[Procedure]

1. Make connections to all input connectors on the front panel of the robot controller.
2. The following type of question will appear on the MPB/RPB screen, so answer as "YES".

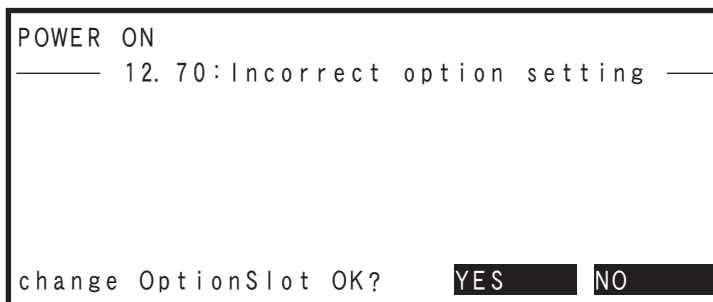

3. If the controller does not operate properly because of a memory error, etc., load the data saved in step 2.1 into the controller. Refer to the controller user's manual for details on loading the data.
If the robot controller is not correctly connected with the DeviceNet system, the message "DeviceNet Link Error" will appear on the MPB/RPB.



NOTE

When using support software "VIP" to load data, refer to the VIP user's manual.

3. Setting the DeviceNet compatible module

To connect the DeviceNet system specification controller to the DeviceNet system, the MAC ID and communication speed must be set with the rotary switch on the DeviceNet compatible module. Carry out the operations explained in section 2.1 to confirm the current MAC ID and communication speed settings.

3.1 Setting the MAC ID

Using the rotary switches MSB and LSB in front of the DeviceNet compatible module, set the MAC ID of the robot controller in the DeviceNet system.



NOTE

The MAC ID for the DeviceNet system can be set in the range of 0 to 63.

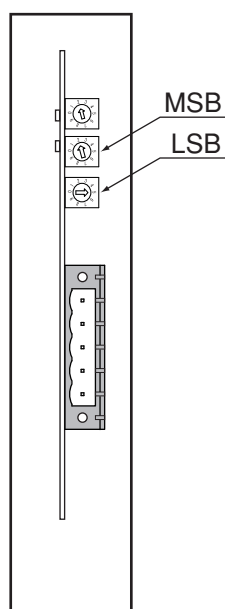

Front of the unit



WARNING

WHEN SETTING THE MAC ID, COMPLETELY SHUT OFF THE POWER SUPPLIED TO THE ROBOT CONTROLLER.

[Procedures]

1. Check the MAC ID of the robot controller in the DeviceNet system.
The MAC ID must be set between 0 and 63.
2. Using a precision flathead screwdriver, set the 2nd digit of the MAC ID on rotary switch MSB.
3. In the same manner, set the 1st digit on rotary switch LSB.



CAUTION

- Make sure that the setting is not duplicated with other settings.
- Never directly touch the conductive sections or electronic parts other than the rotary switch on the DeviceNet compatible module.
- Do not apply impact on the DeviceNet compatible module.
- Do not place water or conductive matters, etc., which could cause damage near the DeviceNet compatible module.
- Accurately set the MAC ID
- When setting the BPS, make sure not to set the rotary switches MSB and LSB by mistake.

3.2 Setting the communication speed

Using the rotary switch BPS in front of the DeviceNet compatible module, set the communication speed for the robot controller in the DeviceNet system.



NOTE

The communication speed must match the DeviceNet system's master module setting.

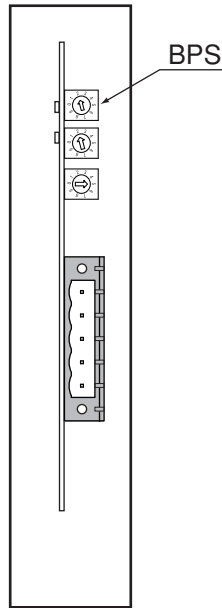

Front of the unit

**WARNING**

WHEN SETTING THE MAC ID, COMPLETELY SHUT OFF THE POWER SUPPLIED TO THE ROBOT CONTROLLER.

[Procedures]

1. Confirm the communication speed for the robot controller in the DeviceNet system. The communication speed must be set between 125K and 500Kbps. The correspondence of the communication speed and switch is shown below.

Switch No.	0	1	2	Other than left setting
Communication speed [bps]	125K	250K	500K	Error

2. Using a precision flathead screwdriver, set the switch No. corresponding to the communication speed with rotary switch BPS.

**CAUTION**

- Never directly touch the conductive sections or electronic parts other than the rotary switch on the DeviceNet compatible module.
- Do not apply impact on the DeviceNet compatible module.
- Do not place water or conductive matters, etc., which could cause damage near the DeviceNet compatible module.
- Accurately set the communication speed.
- When setting the MSB and LSB, make sure not to set the rotary switch BPS by mistake.

4. Noise measures

Two ferrite cores must be mounted on the input power cable when connecting to the DeviceNet system.

4.1 Mounting the ferrite core

Mount two ferrite cores onto the input power cable connected to the input power connector on the front panel of the robot controller.

**WARNING**

COMPLETELY SHUT OFF THE POWER SUPPLY TO THE INPUT POWER CABLE BEFORE STARTING THIS WORK.

[Procedures]

1. Mount the two ferrite cores (supplied) onto the input power cable. The ferrite core should be placed as close to the robot controller body as possible.
2. Fix the mounted ferrite core with an Insulock tie, etc.

**CAUTION**

Securely fix the ferrite core. If the ferrite core is not mounted, trouble could occur with the DeviceNet system operations.

5. Connecting to the DeviceNet system

The DeviceNet system cable must be connected to the DeviceNet compatible module in order to connect to the DeviceNet system.

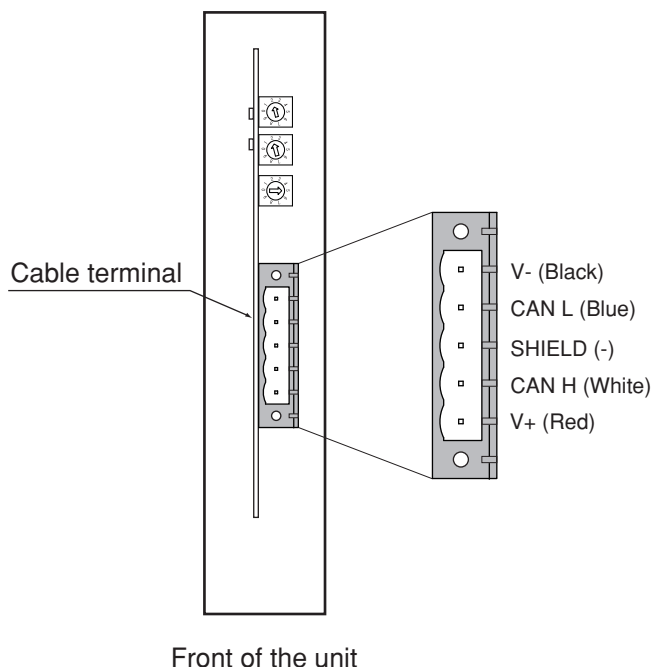

WARNING

BEFORE CONNECTING THE CABLE, COMPLETELY SHUT OFF THE POWER SUPPLIED TO THE ROBOT CONTROLLER.

5.1 Connecting to the cable terminal to the controller

Connect the DeviceNet system cable to the DeviceNet system cable terminal on the DeviceNet compatible module.

[Procedure]

1. Using a flathead screwdriver, completely loosen the two screws on both sides of the DeviceNet system cable terminal, and remove the terminal block section from the DeviceNet compatible module.



CAUTION

Always remove the terminal block section before installing the DeviceNet system cable.

2. Using a flathead screwdriver, securely fix the DeviceNet system cable to the terminal block removed in step 1.

The name of each terminal on the cable terminal block is shown above.

* When connecting a terminator, connect it across CAN H-CAN L.

* A slit to prevent incorrect inverted insertion is provided on the cable terminal block.



CAUTION

- Securely install the DeviceNet system cable.
 - Carefully carry out the work to avoid applying excessive force to the DeviceNet cable.
 - Use a crimp terminal to crimp-connect each wire end of the DeviceNet system cable, so that the cable does not cause an open-circuit fault.
 - Carefully make connections so that the DeviceNet system cable is correctly wired.
-

3. Connect the cable terminal, into which the DeviceNet system cable has been installed, to the DeviceNet compatible module terminal block section on the robot controller, and completely fix with the two screws on both sides using a flathead screwdriver.



CAUTION

Refer to the master module instruction manual for details on the DeviceNet system cable connection.

5.2 Testing the line from the master module

The master module in the DeviceNet system has a function to test the line to the slave module. Using this function, confirm that the robot controller is accurately recognized as a slave module in the DeviceNet system.

Refer to the master module instruction manual for details.



CAUTION

If the line test results indicate a correct connection, place the DeviceNet system cable into a conduit, or fix it with a clamp.

6. Parameter setting for DeviceNet serial I/O board

The following functions are enabled or disabled by setting the parameters for the DeviceNet serial I/O board.

	Parameter	Meaning
1.	[RCX240] Board condition [RCX22x] Serial I/O	Enables or disables the DeviceNet compatible module. When set to "VALID" the controller can be connected to the DeviceNet.
2.	Remote cmd / IO cmd (S105)	Enables or disables the functions of remote commands and I/O commands. When set to "VALID" the remote commands and I/O commands can be used. When set to "INVALID" the remote commands and I/O commands cannot be used. This parameter cannot be set to "VALID" simultaneously with parameter 3. When parameter 4 is set to "Small", the remote command cannot be used, although this parameter can be set to "VALID".
3.	Output MSG to SOW(1)	Enables or disables the function that sends an error message code number, which is displayed on the MPB / RPB, to serial word output SOW(1). When set to "VALID" the error code number will be output to SOW(1). When set to "INVALID" the error code number will not be output to SOW(1). This parameter cannot be set to "VALID" simultaneously with parameter 2. Also, this parameter cannot be set to "VALID" when parameter 4 is set to "Small".
4.	IO size	Selects the number of channels that the DeviceNet compatible module occupies. When set to "Large", 24 channels each are occupied by the input/output. When set to "Small", 2 channels each are occupied by the input/output. This parameter cannot be set to "Small" when parameter 3 is set to "VALID".



NOTE

- IO size setting is supported by Ver. 8.63 onwards of the RCX14x controllers and Ver. 9.09 onwards of the RCX22x controllers.
- When using the controller without connecting to a DeviceNet, set the "board condition" ("serial I/O" for RCX22x) parameter to "INVALID".
- When the "board condition" ("serial I/O" for RCX22x) parameter is set to "INVALID", the dedicated input/output of STD.DIO connector becomes enabled.
- When the "board condition" ("serial I/O" for RCX22x) parameter is set to "VALID", the dedicated input (except DI11 for RCX240) of STD.DIO connector becomes disabled. However, the emergency stop input signal (DI00), interlock input (DI11), and service mode input (DI02) stay enabled.
- For remote commands and I/O commands, refer to the separate command reference manual.
- For a description of codes issued from the "Output MSG to SOW(1)" parameter function, refer to "Error message" in this manual.
- When the "remote cmd / I/O cmd" parameter is set to "VALID", the "Output MSG to SOW(1)" parameter function cannot be used. Likewise, when the "Output MSG to SOW(1)" parameter is set to "VALID", the "remote cmd / I/O cmd" parameter function cannot be used.
- When the IO size is set to "Small" (2CH each of input/output), the I/O commands can be used but the remote commands cannot be used. Note that use of the I/O commands is partly limited.
- When the IO size is set to "Small" (2CH each of input/output), the "Output MSG to SOW(1)" parameter function cannot be used.

6.1 Parameter setting for DeviceNet serial I/O board

[Procedure]

- 1) Press the **F 1** (PARAM) key in "SYSTEM" mode to enter "SYSTEM>PARAM" mode.
- 2) Press the **F 5** (OP. BRD) key in "SYSTEM>PARAM" mode to enter the option board parameter setting mode.
The option boards installed in the controller are displayed in order on the MPB screen.

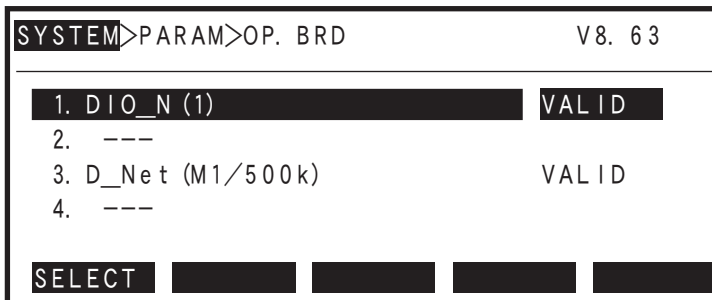

Option boards installed into the option slots are displayed on the MPB screen.

Type	Display	Meaning
Option DIO	DIO_N(n)	An option DIO board of NPN specifications is installed. The number in parentheses is an ID number.
	DIO_P(n)	An option DIO board of PNP specifications is installed. The number in parentheses is an ID number.
Serial I/O	CCLnk(n/m)	A CC-Link unit is installed. Letters in parentheses indicate a station number "n" and a communication speed "m".
	D_Net(n/m)	A DeviceNet unit is installed. Letters in parentheses indicate a MAC ID number "n" and communication speed "m".
	Profi(n/m)	A Profibus unit is installed. Letters in parentheses indicate a station address "n" and communication speed "m".
Network	E_Net	An Ethernet unit is installed.
YC-Link	YCLnk(Mn)	A YC-Link unit is installed. Letters in parentheses indicate a station number "n".

- 3) In "SYSTEM>PARAM>OP. BRD" mode, select the "D_Net" with the cursor (↑/↓) keys and press the **F 1** (SELECT) key.

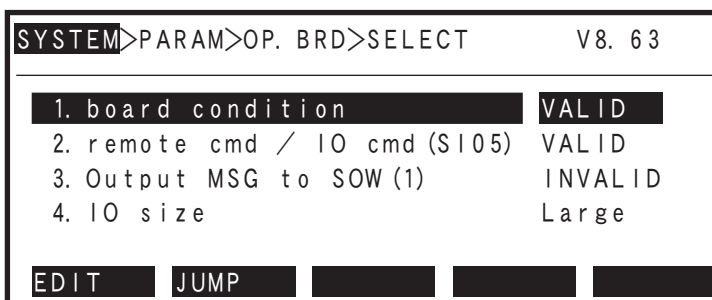

- 4) Select the parameter with the cursor (↑/↓) keys.

```

SYSTEM>PARAM>OP. BRD>SELECT      V8. 63
-----
1. board condition                 VALID
2. remote cmd / IO cmd (SI05)     VALID
3. Output MSG to SOW (1)          INVALID
4. IO size                         Large

EDIT  JUMP  [ ]  [ ]  [ ]

```

- 5) Press the **F 1** (EDIT) key.

```

SYSTEM>PARAM>OP. BRD>SELECT      V8. 63
-----
1. board condition                 VALID
2. remote cmd / IO cmd (SI05)     VALID
3. Output MSG to SOW (1)          INVALID
4. IO size                         Large

INVALID VALID [ ]  [ ]  [ ]

```

- 6) Press the **F 1** (INVALID) or **F 2** (VALID) key.
 When setting the IO size parameter, press the **F 1** (Large) or **F 2** (Small) key.
- 7) Press the **ESC** key to quit the edit mode. To continue setting another parameter, use the cursor (↑/↓) keys to select the parameter.

MEMO

Contents

1.	State when robot controller power is turned ON	3-1
2.	Communication with master module	3-3
2.1	Receiving data	3-3
2.2	Transmitting data	3-5
3.	Direct connection by emulated serialization on parallel DIO	3-8
3.1	Emulated serialization setting on parallel DIO	3-8
4.	Referring to communication data	3-11
4.1	Referring to the data from the programming box	3-11

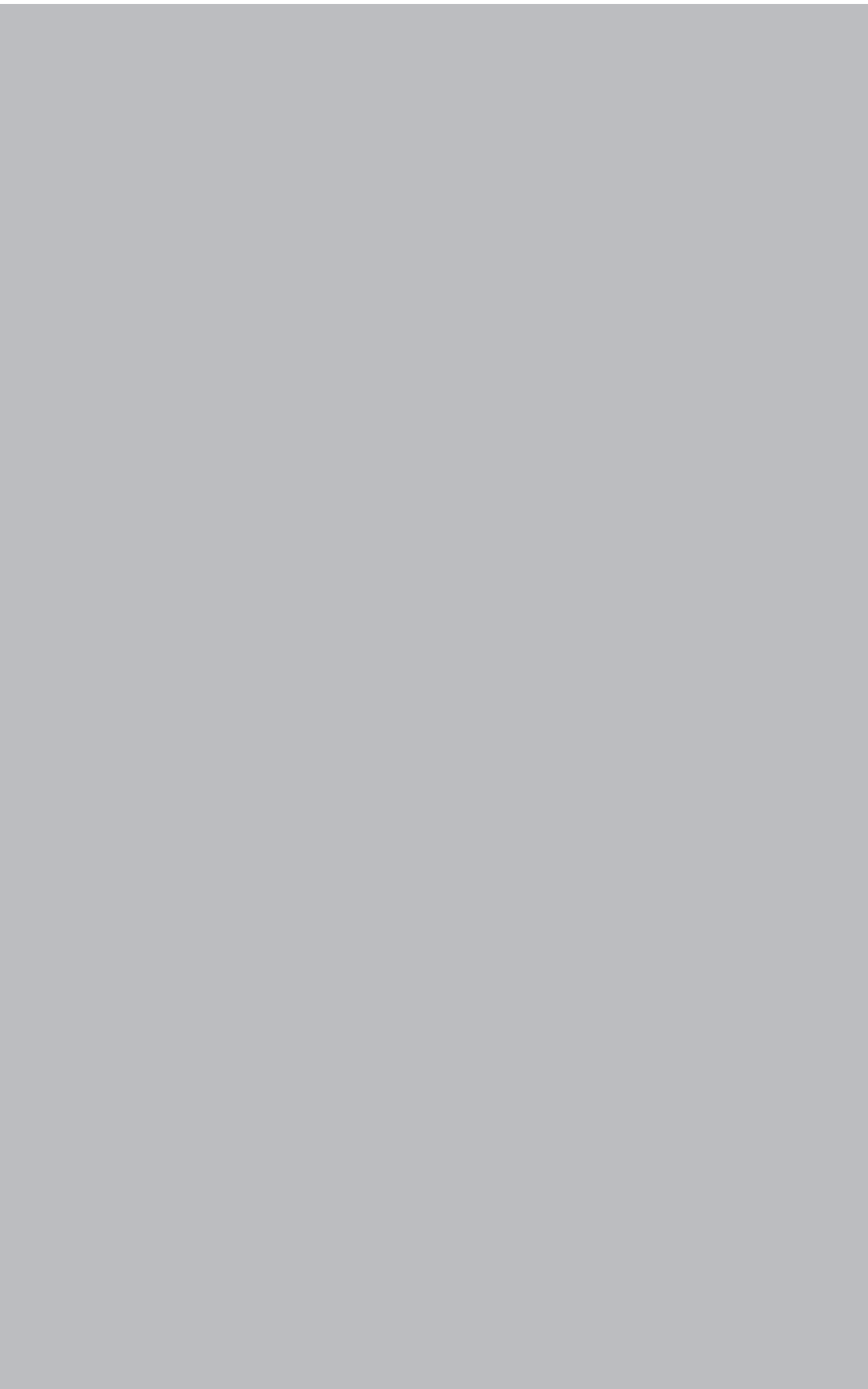

1. State when robot controller power is turned ON

The DeviceNet system specification robot controller **always starts operation in servo OFF state when the power turned ON.**

① When connection to DeviceNet system is correctly established.

The following conditions must be satisfied to correctly connect to the DeviceNet system:

- The DeviceNet system cable must be physically connected
- The MAC ID and communication speed must be correctly set
- The master module is operating normally.

When the robot controller is correctly connected to the DeviceNet system, the normal state will be indicated with the LEDs on the DeviceNet compatible module. At this time, **the emergency stop signal and interlock signal in the DeviceNet system will be validated, so both signals must be turned ON in the connection process.**

The emergency stop terminal in SAFETY connector is always kept valid. On the RCX22x, the interlock signal in SAFETY connector is also valid. On the RCX240, the interlock signal in STD. DIO connector is valid unless the Board condition (external 24V monitor control) of system parameters is set invalid.

When SAFE mode is enabled, service mode input signal is made valid with SI (02) in the DeviceNet system. Service mode input signal to the RCX22x is also made valid with DI (02) in SAFETY connector. On the RCX240, service mode input signal is made valid with DI (02) in SAFETY connector unless the Board condition (external 24V monitor control) of system parameters is set invalid.

② When connection to DeviceNet system is incorrectly established

The following causes can be considered a correct connection with the DeviceNet system cannot be established:

- The DeviceNet system cable is not physically connected
- The MAC ID or communication speed is set incorrectly
- The master module is not operating correctly

When incorrectly connected to the DeviceNet system, an abnormal state will be indicated with the DeviceNet compatible module's LED. This also occurs when the master module is not operating correctly.

The emergency stop signal and interlock signal in the DeviceNet system are invalid in this case, so the robot controller can be operated independently. However, if the correct state has been established even once after the robot controller power was turned ON, the robot controller's emergency stop state cannot be canceled without correctly connecting to the DeviceNet system.

The emergency stop terminal in SAFETY connector is always kept valid. On the RCX22x, the interlock signal in SAFETY connector is also valid. On the RCX240, the interlock signal in STD. DIO connector is valid unless the Board condition (external 24V monitor control) of system parameters is set invalid.

1. State when robot controller power is turned ON

When SAFE mode is enabled, service mode input signal to the RCX22x is made valid with DI (02) in SAFETY connector. On the RCX240, service mode input signal is made valid with DI (02) in SAFETY connector unless the Board condition (external 24V monitor control) of system parameters is set invalid.

Service mode input signal in the DeviceNet system cannot be invalidated when SAFE mode is enabled, so change the service mode setting of system parameters. In this case, take full precautions to prevent improper settings that might lead to a hazardous situation.

* For meanings of LED display, see Chapter 4 in this manual.

Chapter

3

COMMUNICATION

2. Communication with master module

The method for communicating with the master module by using the robot program when the DeviceNet system is correctly connected is explained in this section.

2.1 Receiving data

The master module's output channel data is read via the serial input ports of the robot controller. The table below shows the correspondence of the master module's output channels and the robot controller's serial input ports. The correspondence of the master module's output channels and the robot controller's serial input ports differs depending on whether the IO size is set to "Large" or "Small" by option board parameter.

■ When IO size is set to "Large"

Master module output channel No.	Robot controller serial input port No.	Master module output channel No.	Robot controller serial input port No.
(nCH)	SIW(0)	(n+16CH).07 to 00	SI0(7 to 0)
(n+1CH)	SIW(1)	(n+16CH).15 to 08	SI1(7 to 0)
(n+2CH)	SID(2)	SIW(2)	(n+17CH).07 to 00
(n+3CH)		SIW(3)	(n+17CH).15 to 08
(n+4CH)	SID(4)	SIW(4)	(n+18CH).07 to 00
(n+5CH)		SIW(5)	(n+18CH).15 to 08
(n+6CH)	SID(6)	SIW(6)	(n+19CH).07 to 00
(n+7CH)		SIW(7)	(n+19CH).15 to 08
(n+8CH)	SID(8)	SIW(8)	(n+20CH).07 to 00
(n+9CH)		SIW(9)	(n+20CH).15 to 08
(n+10CH)	SID(10)	SIW(10)	(n+21CH).07 to 00
(n+11CH)		SIW(11)	(n+21CH).15 to 08
(n+12CH)	SID(12)	SIW(12)	(n+22CH).07 to 00
(n+13CH)		SIW(13)	(n+22CH).15 to 08
(n+14CH)	SID(14)	SIW(14)	
(n+15CH)		SIW(15)	

n : Output-area head CH number assigned to master module

■ When IO size is set to "Small"

Master module output channel No.	Robot controller serial input port No.
(nCH).07 to 00	SI0(7 to 0)
(nCH).15 to 08	SI1(7 to 0)
(n+1CH).07 to 00	SI2(7 to 0)
(n+1CH).15 to 08	SI3(7 to 0)

n : Output-area head CH number assigned to master module



CAUTIONS

- Always refer to the PLC manual and check the settings for communication with the master module.
- IO size setting is only supported by Ver. 8.63 onwards of the RCX14x controllers and Ver. 9.09 onwards of the RCX22x controllers. The IO size for earlier version controllers is the same as the "Large" setting.



NOTE

The IO size can be set by option board parameter. Refer to section 6 of chapter 2 for more details.

When reading the bit information from the master module output channel No. with the robot controller, write the following command in the robot program in the same manner as the DI input port.

WAIT command
Assignment statement

Example: To wait for (n+17CH)0 to turn ON when the IO size is set to "Large"
WAIT SI (20) = 1 *The robot program will wait for SI (20) to turn ON.

Example: To read the (n+17CH)0 to (n+17CH)7 data into variable A when the IO size is set to "Large"
A = SI2 () *The SI2 () data will be converted into a decimal and assigned to variable A. If SI2 () is 7Fh, variable A will be 127.



NOTE

The SI statement in the robot language can be defined from SI0 () to SI27 (), but the DeviceNet compatible module accepts from SI0 () to SI15 ().

When reading the word information from the master module's output channel No. with the robot controller, write the following command in the robot program.

Assignment statement

Example: To read the (n+2CH) word data into variable B when the IO size is set to "Large"
B = SIW (2) *The SIW (2) data will be assigned to variable B as a decimal. If SIW (2) is 01FFh, variable B will be 511.

Example: To read the (n+2CH) and (n+3CH) double word data into variable C when the IO size is set to "Large"

C = SID (2) *The SIW (2) and SIW (3) data will be assigned to variable C as a decimal. If SIW (2) is 0010h and SIW (3) is 0001h, variable C will be 65552.



NOTE

The word data written with SOW (n) has the uncoded little endian format.
The double word data written with SOD (n) has the coded little endian format.

2.2 Transmitting data

The serial output port data of the robot controller is transmitted to the master module's input channel. The table below shows the correspondence of the robot controller's serial output ports and the master module's input channels. The correspondence of the robot controller's serial output ports and the master module's input channels differs depending on whether the IO size is set to "Large" or "Small" by option board parameter.

■ When IO size is set to "Large"

Master module input channel No.	Robot controller serial output port No.	Master module input channel No.	Robot controller serial output port No.
(mCH)		(m+16CH).07 to 00	SO0(7 to 0)
(m+1CH)		(m+16CH).15 to 08	SO1(7 to 0)
(m+2CH)	SOD(2)	SOW(2)	(m+17CH).07 to 00
(m+3CH)		SOW(3)	(m+17CH).15 to 08
(m+4CH)	SOD(4)	SOW(4)	(m+18CH).07 to 00
(m+5CH)		SOW(5)	(m+18CH).15 to 08
(m+6CH)	SOD(6)	SOW(6)	(m+19CH).07 to 00
(m+7CH)		SOW(7)	(m+19CH).15 to 08
(m+8CH)	SOD(8)	SOW(8)	(m+20CH).07 to 00
(m+9CH)		SOW(9)	(m+20CH).15 to 08
(m+10CH)	SOD(10)	SOW(10)	(m+21CH).07 to 00
(m+11CH)		SOW(11)	(m+21CH).15 to 08
(m+12CH)	SOD(12)	SOW(12)	(m+22CH).07 to 00
(m+13CH)		SOW(13)	(m+22CH).15 to 08
(m+14CH)	SOD(14)	SOW(14)	
(m+15CH)		SOW(15)	

m : Input-area head CH number assigned to master module

■ When IO size is set to "Small"

Master module input device No.	Robot controller serial output port No.
(mCH).07 to 00	SO0(7 to 0)
(mCH).15 to 08	SO1(7 to 0)
(m+1CH).07 to 00	SO2(7 to 0)
(m+1CH).15 to 08	SO3(7 to 0)

m : Input-area head CH number assigned to master module



CAUTION

- Always refer to the PLC manual and check the settings for communication with the master module.
- IO size setting is only supported by Ver. 8.63 onwards of the RCX14x controllers and Ver. 9.09 onwards of the RCX22x controllers. The IO size for earlier version controllers is the same as the "Large" setting.



NOTE

The IO size can be set by option board parameter. Refer to section 6 of chapter 2 for more details.

When writing the robot controller's bit information into the master module's input channel No., write the following commands in the robot program in the same manner as the DO output port.

SET/RESET command
Assignment statement
OUT command

Example: To turn (m+17CH)0 ON when the IO size is set to "Large"
SET SO (20) or SO (20) = 1 .. *SO (20) will turn ON.

Example: To write the variable A data into (m+17CH)0 to (m+17CH)7 when the IO size is set to "Large"
SO2 () = A *The variable A data will be converted into a binary and assigned to SO 2(). If variable A is 127, SO2 () will be 7Fh.



NOTE

The SO statement in the robot language can be defined from SO2 () to SO27 (), but the DeviceNet compatible module accepts from SO2 () to SO15 ().

When writing the robot controller word information into the master module's input channel No., write the following command in the robot program.

Assignment statement

Example: To write 512 into (m+2CH) as word data when the IO size is set to "Large"
SOW (2) = 512..... *512 is assigned to SOW (2), and SOW (2)
becomes 0200h.

Example: To write 69005 as the double word data into (m+2CH) and (m+3CH) when
the IO size is set to "Large"
SOD (2) = 69905..... *69905 is assigned to SOD (2), SOW (2)
becomes 1111h and SOW (3) becomes
0001h.



NOTE

The word data written with SOW (n) has the uncoded little endian format.
The double word data written with SOD (n) has the coded little endian format.

3. Direct connection by emulated serialization on parallel DIO

The robot controller's parallel input data can be transferred to the serial output data regardless of the robot program. Likewise, the robot controller's serial input data can be transferred to the parallel output data

By using this function, a sensor or relay connected to the parallel I/O of the robot controller can be used like a device connected to the DeviceNet master module.

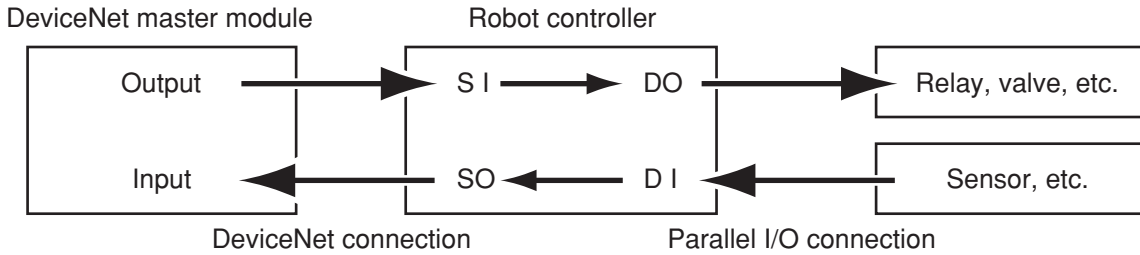

NOTE When the directly connected and set output port is used with the program, the bit information may not become the intended value. Do not use the directly connected and set output port with the program.

3.1 Emulated serialization setting on parallel DIO

The relation of the parallel port and serial port that can be connected is shown below.

Input device such as sensor		Output device such as valve	
DI port → SO port		DO port ← SI port	
D12()	SO2()	DO2()	SI2()
D13()	SO3()	DO3()	SI3()
D14()	SO4()	DO4()	SI4()
D15()	SO5()	DO5()	SI5()

[Operation]

- 1) Press the **F 3** (SIO) key in "SYSTEM > OPTION" mode.

```

SYSTEM>OPTION>SIO                                V8. 01
-----
1. Direct S12 0 -> DO2 0      NO
2. Direct S13 0 -> DO3 0      NO
3. Direct S14 0 -> DO4 0      NO
4. Direct S15 0 -> DO5 0      NO
5. Direct SO2 0 <- DI2 0      NO
EDIT  JUMP
    
```

Valid keys and submenu functions in this mode are as follows.

Valid keys	Menu	Function
Cursor keys (↑/↓)		Selects SIO parameters.
F1	EDIT	Sets SIO parameters.
F2	JUMP	Jumps to specified SIO parameter.



NOTE

When the port specified by SIO is identical with the port used by the program, the output results might be inaccurate.

1. Direct connection from SI n () to DO n ()

Serial port input can be directly connected to parallel port output. The relation of the parallel port and serial port that can be connected is as follows.

Output device such as sensor	
DO port ← SI port	
DO2()	SI2()
DO3()	SI3()
DO4()	SI4()
DO5()	SI5()



NOTE

When the port specified by SIO is identical with the port used by the program, the output results might be inaccurate.

[Operation]

- 1) Select an SI port (from items 1 to 4) in the "SYSTEM > OPTION > SIO" mode.
- 2) Press the **F 1** (EDIT) key.

SYSTEM>OPTION>SIO		V8. 01
1. Direct SI2 0 -> DO2 0		NO
2. Direct SI3 0 -> DO3 0		NO
3. Direct SI4 0 -> DO4 0		NO
4. Direct SI5 0 -> DO5 0		NO
5. Direct SO2 0 <- DI2 0		NO
SET	NO	

- 3) Press the **F 1** (SET) key to enable the connection or the **F 2** (NO) key to cancel the setting.
- 4) Press the **ESC** key to quit setting or select another SI port with the cursor (↑/↓) keys to continue setting.

2. Direct connection from DI n () to SO n ()

Parallel port input can be directly connected to serial port output. The relation of the parallel port and serial port that can be connected is as follows.

Input device such as valve	
DI port → SO port	
D12()	SO2()
D13()	SO3()
D14()	SO4()
D15()	SO5()



NOTE

When the port specified by SIO is identical with the port used by the program, the output results might be inaccurate.

[Operation]

- 1) Select a DI port (from items 5 to 8) in the "SYSTEM > OPTION > SIO" mode.
- 2) Press the **F 1** (EDIT) key.

SYSTEM>OPTION>SIO		V8. 01
4. Direct S15 0 → D05 0		NO
5. Direct SO2 0 ← D12 0		NO
6. Direct SO3 0 ← D13 0		NO
7. Direct SO4 0 ← D14 0		NO
8. Direct SO5 0 ← D15 0		NO
SET	NO	

- 3) Press the **F 1** (SET) key to enable the connection or the **F 2** (NO) key to cancel the setting.
- 4) Press the **ESC** key to quit setting or select another DI port with the cursor (↑/↓) keys to continue setting.

4. Referring to communication data

The ON/OFF information exchanged with the master module can be referred to using the programming box (RPB for RCX22x and RCX240 or MPB for RCX14x; hereafter called "MPB/RPB"). Note that the MPB/RPB display update interval is longer than the DeviceNet data update interval, so if the ON/OFF interval is short, accurate information may not be displayed.

4.1 Referring to the data from the programming box

The data exchanged with the master module can be referred to with the MPB/RPB. The reference unit is the robot controller input/output port No.

SYSTEM		V8. 01	
SI monitor			
SI 0 0	=&B00000111	SI 4 0	=&B11000000
SI 1 0	=&B00001111	SI 5 0	=&B00101000
SI 2 0	=&B00010001	SI 6 0	=&B00000111
SI 3 0	=&B00000100	SI 7 0	=&B00000000
PARAM	CMU	OPTION	INIT
			DIAGNOS

* &Bxxxxxxx corresponds to the 0th bit to 7th bit from right to left.

SYSTEM		V8. 01	
SIW monitor			
SIW (0)	=&H0132	SIW (4)	=&H0000
SIW (1)	=&H0001	SIW (5)	=&H0000
SIW (2)	=&H8000	SIW (6)	=&HFFFF
SIW (3)	=&H0000	SIW (7)	=&H0000
PARAM	CMU	OPTION	INIT
			DIAGNOS

* &Hxxxx expresses a hexadecimal.

[Operation]

- 1) Press the **DISPLAY** key on the MPB/RPB. A screen like that shown below will appear.

SYSTEM		V8. 01	
DI monitor			
DI 0 0	=&B00000111	DI 4 0	=&B11000000
DI 1 0	=&B00001111	DI 5 0	=&B00101000
DI 2 0	=&B00010001	DI 6 0	=&B00000111
DI 3 0	=&B00000100	DI 7 0	=&B00000000
PARAM	CMU	OPTION	INIT
			DIAGNOS

- 2) Press the **DISPLAY** key on the MPB/RPB several times to check the status of SI input ports 0 to 7.

4. Referring to communication data

- 3) Press the **DISPLAY** key on the MPB/RPB once more to check the status of SI input ports 10 to 15.
- 4) Press the **DISPLAY** key on the MPB/RPB twice more to check the status of SO input ports 0 to 7.
- 5) Press the **DISPLAY** key on the MPB/RPB once more to check the status of SO input ports 10 to 15.
- 6) Press the **DISPLAY** key on the MPB/RPB twice more to check the status of SIW input ports 0 to 7.
- 7) Press the **DISPLAY** key on the MPB/RPB once more to check the status of SIW input ports 8 to 15.
- 8) Press the **DISPLAY** key on the MPB/RPB once more to check the status of SOW output ports 0 to 7.
- 9) Press the **DISPLAY** key on the MPB/RPB once more to check the status of SOW output ports 8 to 15.
- 10) To stop checking the input/output ports, press the **ESC** key.

Contents

1.	Items to confirm before starting up DeviceNet system	4-1
2.	Meanings of LEDs on DeviceNet compatible module	4-2
3.	Troubleshooting	4-3
3.1	Robot controller front panel LED confirmation	4-3
3.2	Programming box error display confirmation	4-4
3.3	DeviceNet compatible module LED confirmation	4-5
3.4	Confirmation from master module	4-5
4.	Error messages relating to DeviceNet	4-6

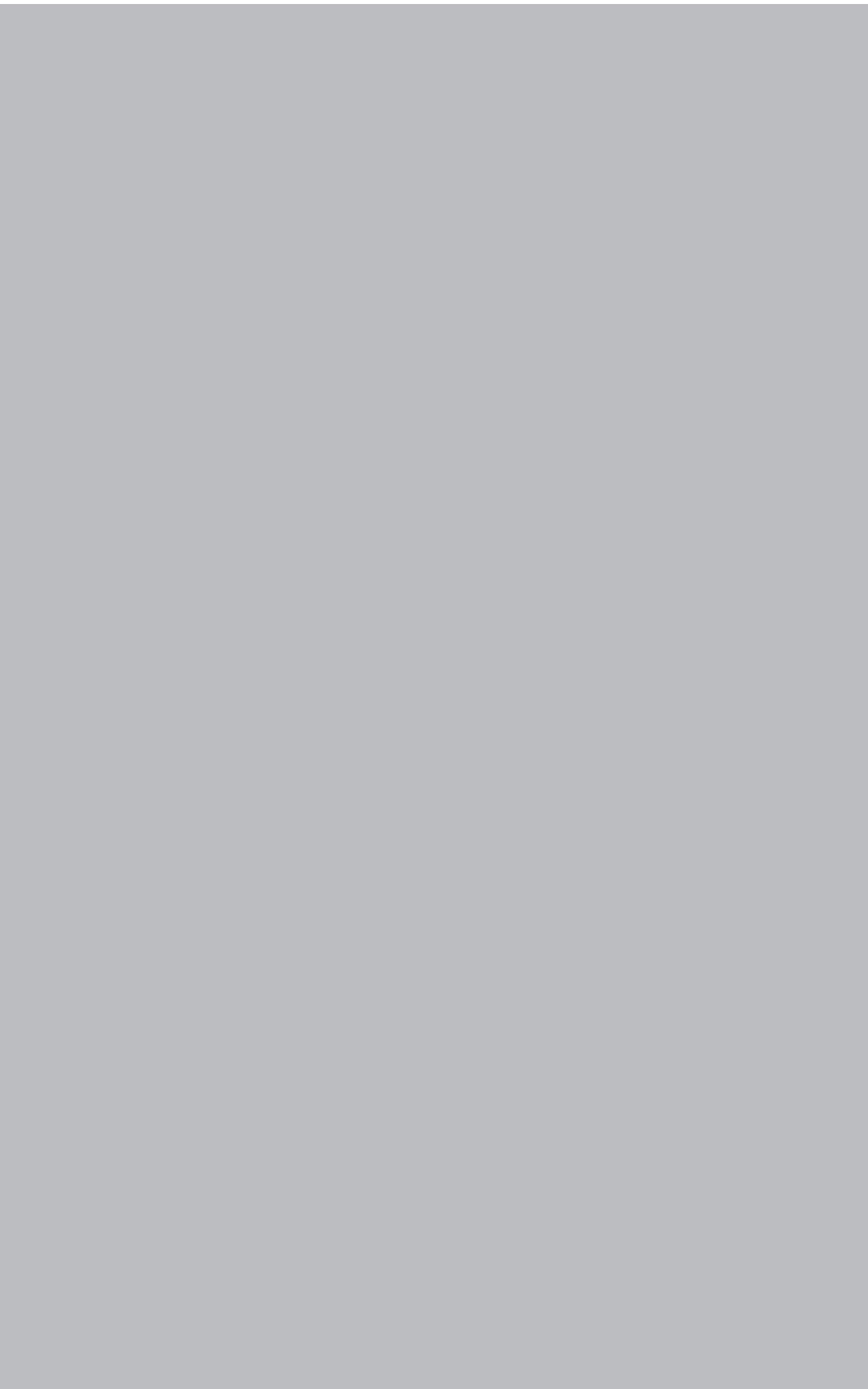

1. Items to confirm before starting up DeviceNet system

Confirm the following items before starting up the DeviceNet system.

	Confirmation details	Check
1	Is the DeviceNet compatible module accurately connected? (Refer to Chapter 2 section 2 or 3.)	
2	Is the robot controller set to the DeviceNet system specifications? (Refer to Chapter 2 section 1.)	
3	Are the DeviceNet compatible module MAC ID and communication speed correctly set? (Refer to Chapter 2 section 1.)	
4	Is the ferrite core connected to the power input cable to the robot controller? (Refer to Chapter 2 section 4.)	
5	Is the DeviceNet system cable accurately connected to the DeviceNet compatible module? (Refer to Chapter 2 section 5.)	
6	Was the line test from the master module correct? (Refer to the master module instruction manual.)	



NOTE

The dedicated input of STD.DIO connector provided on the RCX240 controllers will be disabled except for an interlock signal (DI 11). When the Board condition (external 24V monitor control) of system parameters is set invalid, the interlock signal (DI 11) will also be disabled. On the RCX22x, the dedicated input of STD. DIO connector will be disabled, but the interlock signal (DI 11) in SAFETY connector enabled.

2. Meanings of LEDs on DeviceNet compatible module

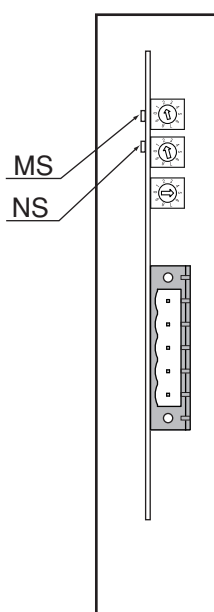

Front of the unit

The LEDs on the DeviceNet compatible module express the following statuses. Use these for confirmation when an error occurs.

Name	Color	State	Meaning
MS	-	OFF	Power is not supplied to DeviceNet compatible module.
	Green	ON	DeviceNet compatible module is normal.
	Red	ON	DeviceNet compatible modules hardware error.
		Flicker	Communication setting is illegal. (A non-designated setting was made.)
NS	-	OFF	The communication power is not supplied. Checking the communication settings.
	Green	ON	Normal communication.
		Flicker	Establishing communication.
	Red	ON	Same MAC ID was found in DeviceNet system.
		Flicker	Cannot exchange data due to disconnection, etc.



CAUTION

After the power is turned ON, MS will light in green and then in red, and NS will light in green and then in red. After that, the LED displays shown on the right will appear. If the power is not supplied to the DeviceNet compatible module, the LED will remain OFF even after the power is turned ON.

3. Troubleshooting

If trouble occurs in the connection with the robot controller while starting up the DeviceNet system or during operation, check the following items in listed order.

- 3-1 Robot controller front panel LED confirmation
- 3-2 Programming box error display confirmation
- 3-3 DeviceNet compatible module LED confirmation
- 3-4 Confirmation from master module

3.1 Robot controller front panel LED confirmation

[Confirmation item 1]

<Confirmation details>

- The "PWR" LED is OFF. (RCX240)
- The "RDY" LED is OFF. (RCX22x)

<Cause>

- Power is not being supplied to the robot controller.

<Countermeasures>

- Measure the voltage at the AC power input terminal of the power connector with a multimeter and check that the rated voltage is being supplied.

* Refer to the robot controller user's manual for the rated voltage for the robot controller.

[Confirmation item 2]

<Confirmation details>

- The "ERR" LED is ON.

<Cause>

- The robot controller is in emergency stop.
- A major error has occurred in the robot controller.

<Countermeasures>

- Confirm the error message displayed on the programming box.
- Take measures by following the troubleshooting section in the robot controller user's manual.

* Refer to the robot controller user's manual for details on the errors.

3.2 Programming box error display confirmation

[Confirmation item 1]

<Confirmation details>

- "DeviceNet Link Error", "DeviceNet Hardware Error" or "DeviceNet Setting Fault" is displayed on the programming modules.
- An addition has been made to the error history.
- Check the error history with the "SYSTEM> DIAGNOS > HISTORY" mode.

<Cause>

- An error has occurred in the DeviceNet system connection.

<Countermeasures>

- Check whether the DeviceNet system cable is disconnected or incorrectly connected.
- Check that the communication power is supplied.
- Check the MAC ID and communication speed settings for the DeviceNet compatible module.
- Confirm that the master module is operating normally.

[Confirmation items 2]

<Confirmation details>

- "DeviceNet Link Error (Explicit)" is displayed on the programming box.
- An addition has been made to the error history.
- Check the error history with the "SYSTEM> DIAGNOS > HISTORY" mode.

<Cause>

- The DeviceNet compatible module was reset by the Explicit message request (Reset request to Identity Obj) from the master module.

<Countermeasures>

- Refer to the master module's manual.

[Confirmation item 3]

<Confirmation details>

- Check whether an error other than "DeviceNet Link Error" is displayed on the programming box. **In this case, this problem is not related to the DeviceNet system connection. Note, however, the message "DeviceNet Link Error" may not appear on the programming box if multiple errors have occurred simultaneously.**

<Cause>

- An error has occurred in the robot controller.

<Countermeasures>

- Check the error message displayed on the programming box.
- Check the error history using the programming box. Check the error history in the "SYSTEM > DIAGNOS > HISTORY" mode using the programming box.
- Take measures by following the troubleshooting section in the robot controller user's manual.

* Refer to the robot controller user's manual for details on the errors.

3.3 DeviceNet compatible module LED confirmation

[Confirmation item 1]

<Confirmation details>

- The LED display on the DeviceNet compatible module is not "MS: Green" and "NS: Green".

<Cause>

- An error has occurred in the DeviceNet system connection.
- Refer to table in section 2 for the meanings of the LED displays.

<Countermeasures>

- Check whether the DeviceNet system cable is disconnected or incorrectly connected, and whether the terminator is connected and the communication power is supplied.
- Check whether the DeviceNet system cable is laid near the main circuit or power cable, or whether it is bundled with these.
- Check that the ferrite core is connected to the robot controller's power supply cable.
- Check the MAC ID and communication speed settings for the DeviceNet compatible module.
- Confirm that the master module is operating normally.

3.4 Confirmation from master module

[Confirmation item 1]

<Confirmation details>

- Using the master module's line test function, confirm robot controller is correctly connected to the DeviceNet system.

* Refer to the master module instruction manual for details on the line test.

[Confirmation item 2]

<Confirmation details>

- Using the master module's line test function, check whether an error has occurred in the robot controller's DeviceNet connection.

<Cause>

- The ferrite core for noise measures is not connected.
- The DeviceNet cable is laid near sources of noise such as the power cable.

<Countermeasures>

- Connect the ferrite core for noise measures onto the input power cable.
- Wire the DeviceNet cable away from noise sources such as the power cable.

4. Error messages relating to DeviceNet

This section describes error messages relating to DeviceNet compatible units. For other messages, refer to robot controller user's manuals. When an error occurs, an error message appears on the message line (2nd line) of the MPB and RPB screen.

12.1 : Emg.stop on

Code : &H0C01

Meaning/Cause :

- a. MPB emergency stop button was pressed.
- b. Emergency stop terminals on SAFETY connector are open (emergency stop status).
- c. MPB or terminator is not connected to MPB connector.
- d. SAFETY connector is not connected.
- e. SI(00) is not ON.
- f. Error in connection to DeviceNet system.
- g. RPB emergency stop button is pressed.
- h. RPB or terminator is not connected to RPB connector.

Action :

1. Release the MPB emergency stop button.
2. Close the emergency stop terminals on SAFETY connector.
3. Connect MPB or terminator to MPB connector.
4. Attach the SAFETY connector.
5. Set SI(00) to ON.
6. Correct the connection to DeviceNet system.
7. Release the RPB emergency stop button.
8. Connect RPB or terminator to RPB connector.

12.2 : Interlock on

Code : &H0C02

Meaning/Cause :

- a. Program was executed or moving of axis attempted with interlock signal still input.
- b. Interlock signal turned ON during execution of program or axis movement.
- c. DC 24V is supplied to STD.DIO connector and DI(11) is not turned ON while using RCX240.
- d. SI(11) is not ON.
- e. Error in connection to DeviceNet system.
- f. DI(11) is not turned ON while using RCX22x.

Action :

1. Cancel the interlock signal, and execute program or move axis.
2. Set DI(11) on STD.DIO connector to ON. (RCX240)
3. Set SI(11) to ON.
4. When not using STD.DIO, disable (invalid) the "Watch on STD.DO DC24V" parameter in SYSTEM mode. (RCX240)
5. Correct the connection to DeviceNet system.
6. Set DI(11) on SAFETY connector to ON. (RCX22x)

12.16: DeviceNet link error

Code	: &H0C10
Meaning/Cause	: a. Error in cable for DeviceNet system. b. Wrong MacID and communication speed setting for DeviceNet system. c. Power supply for communication is not supplied. d. Master station sequencer power is turned off, or master station sequencer has stopped operating, is in abnormal operation or at fault. e. Breakdown in DeviceNet compatible unit.
Action	: 1. Check for a broken wire, no connection, miswiring or specifications (cable length) of DeviceNet cable. 2. Check the Mac ID and communication speed setting. 3. Check if the master station sequencer power is supplied. 4. Check if the maser station sequence is operating normally. 5. Replace the DeviceNet compatible unit.

12.17: DeviceNet hardware error

Code	: &H0C11
Meaning/Cause	: a. DeviceNet compatible unit is at fault.
Action	: 1. Replace the DeviceNet compatible unit.

12.18: Incorrect DeviceNet setting

Code	: &H0C12
Meaning/Cause	: a. Wrong MacID and communication speed setting.
Action	: 1. Check the MacID and communication speed setting.

12.19: DeviceNet link error (Explicit)

Code	: &H0C13
Meaning/Cause	: a. DeviceNet board was reset by an explicit message from a client (request for identity object).
Action	:

12.70: Incorrect option setting

Code	: &H0C46
Meaning/Cause	: a. Error in DIP switch setting on option unit. b. Mismatched option units have been installed. c. Cannot identify the installed option unit.
Action	: 1. Check the DIP switch settings on the option unit. 2. Install the correct option units. 3. Replace the option unit.

MEMO

Contents

1. Profile	5-1
1.1 When IO size is set to "Large"	5-1
1.2 When IO size is set to "Small"	5-4
2. Details of input/output signals	5-5
3. Dedicated input/output signal timing chart	5-11
3.1 Servo ON and emergency stop	5-11
3.2 AUTO mode changeover, program reset and program execution	5-12
3.3 Stopping with program interlock	5-14
4. Sample program	5-16
5. DeviceNet compatible module specifications	5-27
6. DeviceNet specifications	5-28

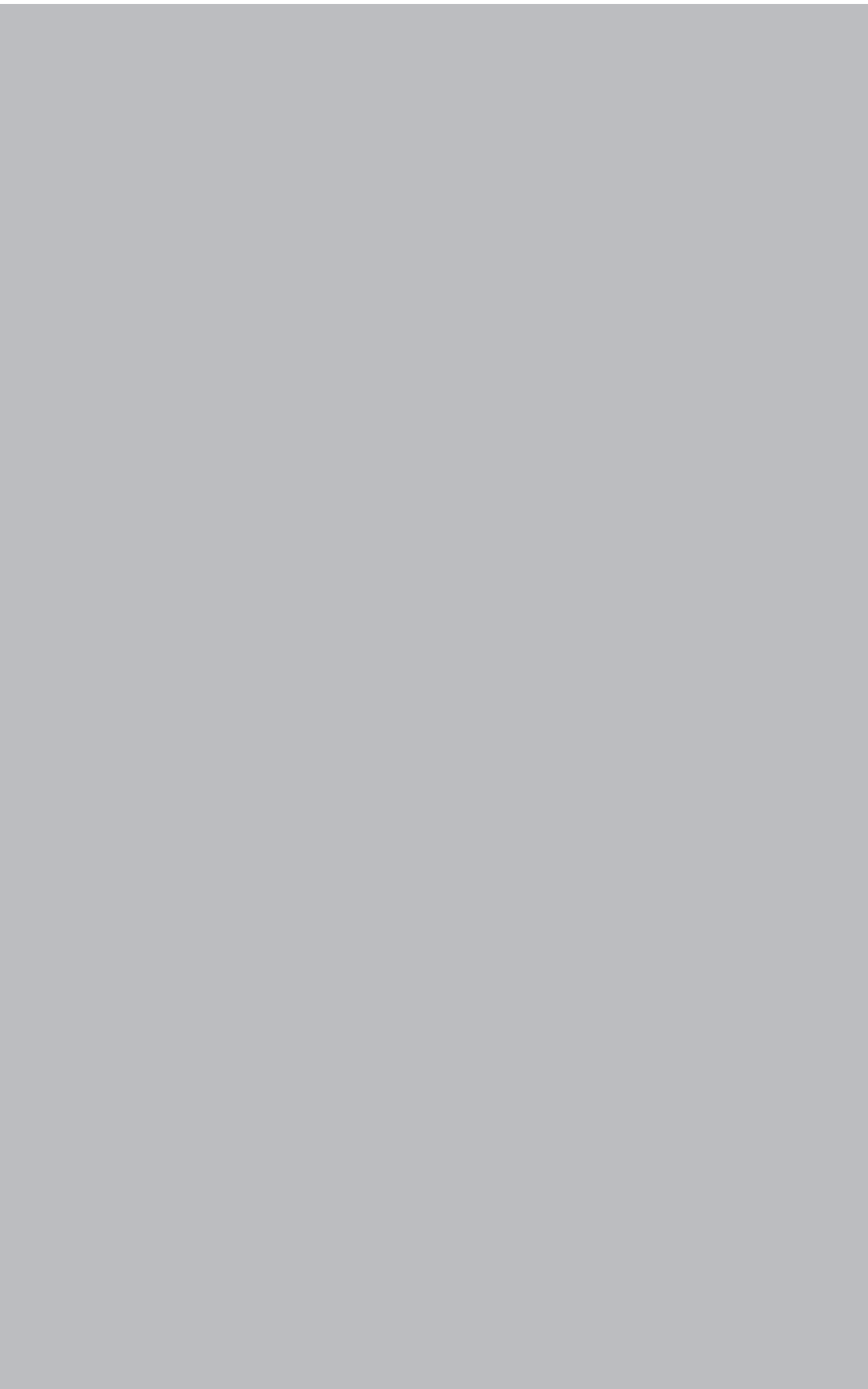

1. Profile



CAUTION

- Explanations are given based on the channels for the OMRON master module. Refer to the respective manuals when using other master module brands.
- IO size setting is only supported by Ver. 8.63 onwards of the RCX14x controllers and Ver. 9.09 onwards of the RCX22x controllers. The bit I/O and word I/O for earlier version controllers are the same as those of the "Large" IO size setting.



NOTE

The IO size can be set by option board parameter. Refer to section 6 of chapter 2 for more details.

1.1 When IO size is set to "Large"

YAMAHA robot controller

■ Bit input/output

Slave → Master			Master → Slave				
Channel No.	bit	Signal name	Channel No.	bit	Signal name		
(m+16CH)	0	SO(00)	(n+16CH)	0	SI(00)	Emergency stop input status output	Emergency stop input
	1	SO(01)		1	SI(01)	CPU_OK status output	Servo ON input
	2	SO(02)		2	SI(02)	Servo ON status output	Service mode input
	3	SO(03)		3	SI(03)	Alarm status output	Step execution input *1
	4			4		Reserved	Reserved
	5			5	SI(05)	Reserved	IO command execution trigger input
	6			6		Reserved	Reserved
	7			7		Reserved	Reserved
	8	SO(10)		8	SI(10)	AUTO mode status output	Sequence control input
	9	SO(11)		9	SI(11)	Return-to-origin complete status output	Interlock input
	10	SO(12)		10	SI(12)	Sequence program execution status output	Robot program start input
	11	SO(13)		11	SI(13)	Robot program execution status output	AUTO mode input
	12	SO(14)		12	SI(14)	RCX141/221	Absolute reset input *2
	13	SO(15)		Battery alarm output *1		RCX142/222	Return-to-origin input *3
						RCX240	Return-to-origin input
14	SO(16)	13	SI(15)	Program reset input	IO command execution judgment output		
15	SO(17)	Output during IO command execution	14	SI(16)	MANUAL mode input		
				15	SI(17)	RCX141/221	Return-to-origin input
						RCX142/222	Absolute reset input
RCX240	Absolute reset / Return-to-origin input *4						

(continued to next page)

Slave → Master				Master → Slave			
Channel No.	bit	Signal name		Channel No.	bit	Signal name	
(m+17CH)	0 to 7	SO(20) to SO(27)	General-purpose output	(n+17CH)	0 to 7	SI(20) to SI(27)	General-purpose input
	8 to 15	SO(30) to SO(37)	General-purpose output		8 to 15	SI(30) to SI(37)	General-purpose input
(m+18CH)	0 to 7	SO(40) to SO(47)	General-purpose output	(n+18CH)	0 to 7	SI(40) to SI(47)	General-purpose input
	8 to 15	SO(50) to SO(57)	General-purpose output		8 to 15	SI(50) to SI(57)	General-purpose input
(m+19CH)	0 to 7	SO(60) to SO(67)	General-purpose output	(n+19CH)	0 to 7	SI(60) to SI(67)	General-purpose input
	8 to 15	SO(70) to SO(77)	General-purpose output		8 to 15	SI(70) to SI(77)	General-purpose input
(m+20CH)	0 to 7	SO(100) to SO(107)	General-purpose output	(n+20CH)	0 to 7	SI(100) to SI(107)	General-purpose input
	8 to 15	SO(110) to SO(117)	General-purpose output		8 to 15	SI(110) to SI(117)	General-purpose input
(m+21CH)	0 to 7	SO(120) to SO(127)	General-purpose output	(n+21CH)	0 to 7	SI(120) to SI(127)	General-purpose input
	8 to 15	SO(130) to SO(137)	General-purpose output		8 to 15	SI(130) to SI(137)	General-purpose input
(m+22CH)	0 to 7	SO(140) to SO(147)	General-purpose output	(n+22CH)	0 to 7	SI(140) to SI(147)	General-purpose input
	8 to 15	SO(150) to SO(157)	General-purpose output		8 to 15	SI(150) to SI(157)	General-purpose input
(m+23CH)	0 to 15		Reserved	(n+23CH)	0 to 15		Reserved

m : Input-area head CH number assigned to master module
n : Output-area head CH number assigned to master module

- *1: Step execution input (SI(03)) and battery alarm output (SO(15)) are only supported by the RCX22x.
- *2: Used in YC-Link only when RCX141 or RCX221 is used with SR1-X.
- *3: Used in YC-Link only when RCX142 or RCX222 is used with SR1-P.
- *4: Used for "absolute reset" or "absolute reset / return-to-origin" depending on parameter (DI17 mode) setting.

■ Word input/output

Slave → Master				Master → Slave			
Channel No.	Signal name			Channel No.	Signal name		
(mCH)		SOW(0)	Dedicated output	(nCH)		SIW(0)	Dedicated input
(m+1CH)		SOW(1)	Dedicated output	(n+1CH)		SIW(1)	Dedicated input
(m+2CH)	SOD(2)	SOW(2)	General-purpose output	(n+2CH)	SID(2)	SIW(2)	General-purpose input
(m+3CH)		SOW(3)	General-purpose output	(n+3CH)		SIW(3)	General-purpose input
(m+4CH)	SOD(4)	SOW(4)	General-purpose output	(n+4CH)	SID(4)	SIW(4)	General-purpose input
(m+5CH)		SOW(5)	General-purpose output	(n+5CH)		SIW(5)	General-purpose input
(m+6CH)	SOD(6)	SOW(6)	General-purpose output	(n+6CH)	SID(6)	SIW(6)	General-purpose input
(m+7CH)		SOW(7)	General-purpose output	(n+7CH)		SIW(7)	General-purpose input
(m+8CH)	SOD(8)	SOW(8)	General-purpose output	(n+8CH)	SID(8)	SIW(8)	General-purpose input
(m+9CH)		SOW(9)	General-purpose output	(n+9CH)		SIW(9)	General-purpose input
(m+10CH)	SOD(10)	SOW(10)	General-purpose output	(n+10CH)	SID(10)	SIW(10)	General-purpose input
(m+11CH)		SOW(11)	General-purpose output	(n+11CH)		SIW(11)	General-purpose input
(m+12CH)	SOD(12)	SOW(12)	General-purpose output	(n+12CH)	SID(12)	SIW(12)	General-purpose input
(m+13CH)		SOW(13)	General-purpose output	(n+13CH)		SIW(13)	General-purpose input
(m+14CH)	SOD(14)	SOW(14)	General-purpose output	(n+14CH)	SID(14)	SIW(14)	General-purpose input
(m+15CH)		SOW(15)	General-purpose output	(n+15CH)		SIW(15)	General-purpose input

m : Input-area head CH number assigned to master module
n : Output-area head CH number assigned to master module

1.2 When IO size is set to "Small"

■ Bit input/output

Slave → Master				Master → Slave				
Channel No.	bit	Signal name		Channel No.	bit	Signal name		
(mCH)	0	SO(00)	Emergency stop input status output	(nCH)	0	SI(00)	Emergency stop input	
	1	SO(01)	CPU_OK status output		1	SI(01)	Servo ON input	
	2	SO(02)	Servo ON status output		2	SI(02)	Service mode input	
	3	SO(03)	Alarm status output		3	SI(03)	Step execution input *1	
	4		Reserved		4		Reserved	
	5		Reserved		5	SI(05)	IO command execution trigger input	
	6		Reserved		6		Reserved	
	7		Reserved		7		Reserved	
	8	SO(10)	AUTO mode status output		8	SI(10)	Sequence control input	
	9	SO(11)	Return-to-origin complete status output		9	SI(11)	Interlock input	
	10	SO(12)	Sequence program execution status output		10	SI(12)	Robot program start input	
	11	SO(13)	Robot program execution status output		11	SI(13)	AUTO mode input	
	12	SO(14)	Program reset status output		12	SI(14)	RCX141/221	Absolute reset input *2
	13	SO(15)	Battery alarm output *1		RCX142/222		Return-to-origin input *3	
	14	SO(16)	IO command execution judgment output		RCX240		Return-to-origin input	
15	SO(17)	Output during IO command execution	13	SI(15)	Program reset input			
(m+1CH)	0 to 7	SO(20) to SO(27)	General-purpose output	(n+1CH)	0 to 7	SI(20) to SI(27)	General-purpose input	
	8 to 15	SO(30) to SO(37)	General-purpose output		8 to 15	SI(30) to SI(37)	General-purpose input	
				15	SI(17)	RCX141/221	Return-to-origin input	
						RCX142/222	Absolute reset input	
						RCX240	Absolute reset / Return-to-origin input *4	

m : Input-area head CH number assigned to master module
 n : Output-area head CH number assigned to master module

- *1: Step execution input (SI(03)) and battery alarm output (SO(15)) are only supported by the RCX22x.
- *2: Used in YC-Link only when RCX141 or RCX221 is used with SR1-X.
- *3: Used in YC-Link only when RCX142 or RCX222 is used with SR1-P.
- *4: Used for "absolute reset" or "absolute reset / return-to-origin" depending on parameter (DI17 mode) setting.

2. Details of input/output signals



CAUTION

- Explanations are given based on the channels for the OMRON master module. Refer to the respective manuals when using other manufacturers' master modules.
- The number of occupied channels differs depending on the IO size setting (Large or Small). IO size setting is only supported by Ver. 8.63 onwards of the RCX14x controllers and Ver. 9.09 onwards of the RCX22x controllers. The IO size for earlier version controllers is the same as the "Large" setting.



NOTE

The IO size can be set by option board parameter. Refer to section 6 of chapter 2 for more details.

■ Bit output

Channel No.		Signal name		Details
Large	Small			
(m+16CH)0	(mCH)0	SO(00)	Emergency stop input status output	Turns ON when robot controller is in emergency stop state.
(m+16CH)1	(mCH)1	SO(01)	CPU_OK status output	Turns ON when robot controller is in normal state.
(m+16CH)2	(mCH)2	SO(02)	Servo ON status output	Turns ON when robot controller motor power is ON.
(m+16CH)3	(mCH)3	SO(03)	Alarm status output	Turns ON when robot controller is in following state: <ul style="list-style-type: none"> • Serious error occurred in robot controller. • Emergency stop input OFF
(m+16CH)8	(mCH)8	SO(10)	AUTO mode status output	Turns ON when selected mode is AUTO mode. Turns OFF when other mode is selected.
(m+16CH)9	(mCH)9	SO(11)	Return-to-origin complete status output	Turns ON when robot has completed return-to-origin.
(m+16CH)10	(mCH)10	SO(12)	Sequence program execution status output	Turns ON while sequence program is executed.
(m+16CH)11	(mCH)11	SO(13)	Robot program execution status output	Turns ON while robot program is executed.
(m+16CH)12	(mCH)12	SO(14)	Program reset status output	Turns ON when robot program has been reset. Turns OFF when robot program starts.
(m+16CH)13	(mCH)13	SO(15)	Battery alarm output	Turns ON when system backup battery (RCX22x) or absolute battery (RCX222) voltage is low.
(m+16CH)14	(mCH)14	SO(16)	IO command execution judgment output	Turns OFF while executing the IO command. After executing the IO command turns ON if normal, and stays OFF if abnormal.
(m+16CH)15	(mCH)15	SO(17)	Output during IO command execution	Turns ON while executing the IO command.

(continued to next page)

2. Details of input/output signals

Channel No.		Signal name		Details
Large	Small			
(m+17CH)0 to (m+17CH)7	(m+1CH)0 to (m+1CH)7	SO(20) to SO(27)	General-purpose output	General-purpose output turns ON/OFF when value is assigned to SO port, or SET/RESET command or OUT command is executed.
(m+17CH)8 to (m+17CH)15	(m+1CH)8 to (m+1CH)15	SO(30) to SO(37)	General-purpose output	
to		to	to	
(m+22CH)8 to (m+22CH)15		SO(150) to SO(157)	General-purpose output	

m : Input-area head CH number assigned to master module



NOTE

- Battery alarm output (SO(15)) is only supported by the RCX22x.
- When the area check output function is used, the area check outputs can be assigned to the following general-purpose outputs depending on the software version and I/O size.

Software version	IO size	Port to which area check output can be assigned	
RCX240x Ver. 10.10 onwards, RCX22x Ver. 9.22 onwards	Large	SO(20) to SO(157)	In terms of specifications, SO(40) to SO(157) do not exist as hardware, so these are not output to external devices but can be used as internal outputs.
	Small	SO(20) to SO(37)	
Controllers other than the above version		SO(20) to SO(27)	

- When the IO size is set to "Small", only SO(20) to SO(37) of general-purpose outputs are available.

■ Bit input

Channel No.		Signal name		Details
Large	Small			
(n+16CH)0	(nCH)0	SI(00)	Emergency stop input	Turn OFF to trigger emergency stop on controller. Keep turned ON during normal operation.
(n+16CH)1	(nCH)1	SI(01)	Servo ON input	Turn ON to cancel emergency stop and turn ON the robot servo motor. Servo-ON is executed when this input is switched from OFF to ON. Emergency stop input [SI(00)] must have been ON, and emergency stop state in the robot controller (emergency stop terminal of SAFETY connector, etc.) canceled.
(n+16CH)2	(nCH)2	SI(02)	Service mode input	Turn OFF to enter the controller in service mode. Keep turned ON during normal operation. (Effective only when SAFE mode is enabled.) (In SAFE mode enabled, dedicated input might be disabled depending on service mode parameter setting.)
(n+16CH)3	(nCH)3	SI(03)	Step execution input	Turn ON to execute a step in the program during AUTO mode. One line of the program is executed when this input is changed from OFF to ON.

(continued to next page)

2. Details of input/output signals

Channel No.		Signal name		Details	
Large	Small				
(n+16CH)5	(nCH)5	SI(05)	IO command execution trigger input	Turn from OFF to ON to execute IO command. Always turn ON after IO command is set to general-purpose input.	
(n+16CH)8	(nCH)8	SI(10)	Sequence control input	Turn ON to execute sequence program in the robot controller. Sequence program is executed when this input is ON.	
(n+16CH)9	(nCH)9	SI(11)	Interlock input	Turn OFF to stop execution of robot program. Keep turned ON to continue program execution.	
(n+16CH)10	(nCH)10	SI(12)	Robot program start input	Turn ON to execute robot program. Robot program is executed when this input is switched from OFF to ON. Robot controller must be in AUTO mode.	
(n+16CH)11	(nCH)11	SI(13)	AUTO mode input	Turn ON to select AUTO mode. Robot program enters AUTO mode when this input is switched from OFF to ON.	
(n+16CH)12	(nCH)12	SI(14)	RCX141/221	Absolute reset input * For YC-Link where RCX141/221 is used with SR1-X	Turn ON to perform absolute reset of robot. Absolute reset is performed when this input is switched from OFF to ON, except for axes that use mark method for return-to-origin. Absolute reset cannot be performed by dedicated input if return-to-origin is incomplete on axes that use mark method. Robot controller mode must be in MANUAL mode.
			RCX142/222	Return-to-origin input * For YC-Link where RCX142/222 is used with SR1-P	Turn ON to perform return-to-origin on incremental type axes or semi-absolute type axes. When this input is switched from OFF to ON, return-to-origin is performed on incremental type axes or absolute search is performed on semi-absolute type axes.
			RCX240	Return-to-origin input	This input is for axes whose return-to-origin method is sensor or stroke-end (torque detection) method. Robot controller mode must be in MANUAL mode.
(n+16CH)13	(nCH)13	SI(15)	Program reset input	Turn ON to reset robot program. Program reset is executed when this input is switched from OFF to ON. Robot controller must be in AUTO mode.	
(n+16CH)14	(nCH)14	SI(16)	MANUAL mode input	Turn ON to select MANUAL mode. Robot program enters MANUAL mode when this input is switched from OFF to ON.	

(continued to next page)

2. Details of input/output signals

Channel No.		Signal name		Details	
Large	Small				
(n+16CH)15	(nCH)15	SI(17)	RCX141/221	Return-to-origin input	Turn ON to perform return-to-origin on incremental type axes or semi-absolute type axes. When this input is switched from OFF to ON, return-to-origin is performed on incremental type axes or absolute search is performed on semi-absolute type axes. This input is for axes whose return-to-origin method is sensor or stroke-end (torque detection) method. Robot controller mode must be in MANUAL mode.
			RCX142/222	Absolute reset input	Turn ON to perform absolute reset of robot. Absolute reset is performed when this input is switched from OFF to ON, except for axes that use mark method for return-to-origin. Absolute reset cannot be performed by dedicated input if return-to-origin is incomplete on axes that use mark method. Robot controller mode must be in MANUAL mode.
			RCX240	Absolute reset / Return-to-origin input	Used for "absolute reset" or "absolute reset / return-to-origin" depending on parameter (DI17 mode) setting. <ul style="list-style-type: none"> When set to "ABS" (absolute reset) Turn ON to perform absolute reset of robot. Absolute reset is performed when this input is switched from OFF to ON, except for axes that use mark method for return-to-origin. Absolute reset cannot be performed by dedicated input if return-to-origin is incomplete on axes that use mark method. Robot controller mode must be in MANUAL mode. When set to "ABS/ORG" (absolute reset / return-to-origin) When only absolute type axes are used, switching this input from OFF to ON performs absolute reset. When only incremental type and semi-absolute type axes are used, switching this input from OFF to ON performs return-to-origin on the incremental axes and absolute search on the semi-absolute type axes. When absolute type, incremental type and semi-absolute type axes are used, absolute reset is first performed on the absolute axes and then return-to-origin is performed on the incremental type and semi-absolute type axes.
(n+17CH)0 to (n+17CH)7	(n+1CH)0 to (n+1CH)7	SI(20) to SI(27)	General-purpose input	Use ON/OFF of these general-purpose inputs for referencing the SI port value and executing a WAIT command.	
(n+17CH)8 to (n+17CH)15	(n+1CH)8 to (n+1CH)15	SI(30) to SI(37)	General-purpose input		
to		to	to		
(n+22CH)8 to (n+22CH)15		—	General-purpose input		

n: Output-area head CH number assigned to master module



NOTE

- Step execution input (SI(03)) is only supported by the RCX22x.
 - When the IO size is set to "Small", only SI(20) to SI(37) of general-purpose inputs are available.
 - When using SI(17) as return-to-origin input with the RCX240 which is used as a replacement for the RCX141 or RCX221, use SI(17) as "absolute reset / return-to-origin".
 - When the RCX240 is used with a robot whose axis configuration includes absolute type, incremental type and/or semi-absolute type axes, and if SI(17) is used for "absolute reset / return-to-origin", then absolute reset is performed on the absolute reset axis each time return-to-origin is performed on the incremental type and/or semi-absolute type axes. So, if the robot axis configuration includes absolute type, incremental type and/or semi-absolute type axes, we recommend using SI (17) to perform absolute reset and SI(14) to perform return-to-origin.
 - Return-to-origin input and absolute reset input can also be executed in AUTO mode by changing the execution level. Refer to the controller user's manual for more details.
-

3. Dedicated input/output signal timing chart

Word input

Channel No.		Name			Details	
Large	Small					
(nCH)	/		SIW(0)	Dedicated input	Used as the remote command area.	
(n+1CH)			SIW(1)		Used as the remote command's data area.	
(n+2CH)		SID(2)		SIW(2)	General-purpose input	Used to input word or double word data from SIW or SID port. Or, used as remote command's command data area.
(n+3CH)				SIW(3)		
(n+4CH)		SID(4)		SIW(4)		
(n+5CH)				SIW(5)		
(n+6CH)		SID(6)		SIW(6)		
(n+7CH)				SIW(7)		
(n+8CH)		SID(8)		SIW(8)		
(n+9CH)				SIW(9)		
(n+10CH)		SID(10)		SIW(10)		
(n+11CH)				SIW(11)		
(n+12CH)		SID(12)		SIW(12)		
(n+13CH)				SIW(13)		
(n+14CH)		SID(14)		SIW(14)		
(n+15CH)				SIW(15)		

n: Output-area head CH number assigned to master module



CAUTION

When the IO size is set to "Small", word input (SID and SIW) cannot be used.

Word output

Channel No.		Name			Details	
Large	Small					
(mCH)	/		SOW(0)	Dedicated input	Used as the remote command's status area.	
(m+1CH)			SOW(1)		Used as the remote command's error code area.	
(m+2CH)		SOD(2)		SOW(2)	General-purpose input	Used to output word or double word data from SOW or SOD port. Or, used as remote command's response area.
(m+3CH)				SOW(3)		
(m+4CH)		SOD(4)		SOW(4)		
(m+5CH)				SOW(5)		
(m+6CH)		SOD(6)		SOW(6)		
(m+7CH)				SOW(7)		
(m+8CH)		SOD(8)		SOW(8)		
(m+9CH)				SOW(9)		
(m+10CH)		SOD(10)		SOW(10)		
(m+11CH)				SOW(11)		
(m+12CH)		SOD(12)		SOW(12)		
(m+13CH)				SOW(13)		
(m+14CH)		SOD(14)		SOW(14)		
(m+15CH)				SOW(15)		

m: Input-area head CH number assigned to master module



CAUTION

When the IO size is set to "Small", word output (SOD and SOW) cannot be used.

3. Dedicated input/output signal timing chart

3.1 Servo ON and emergency stop

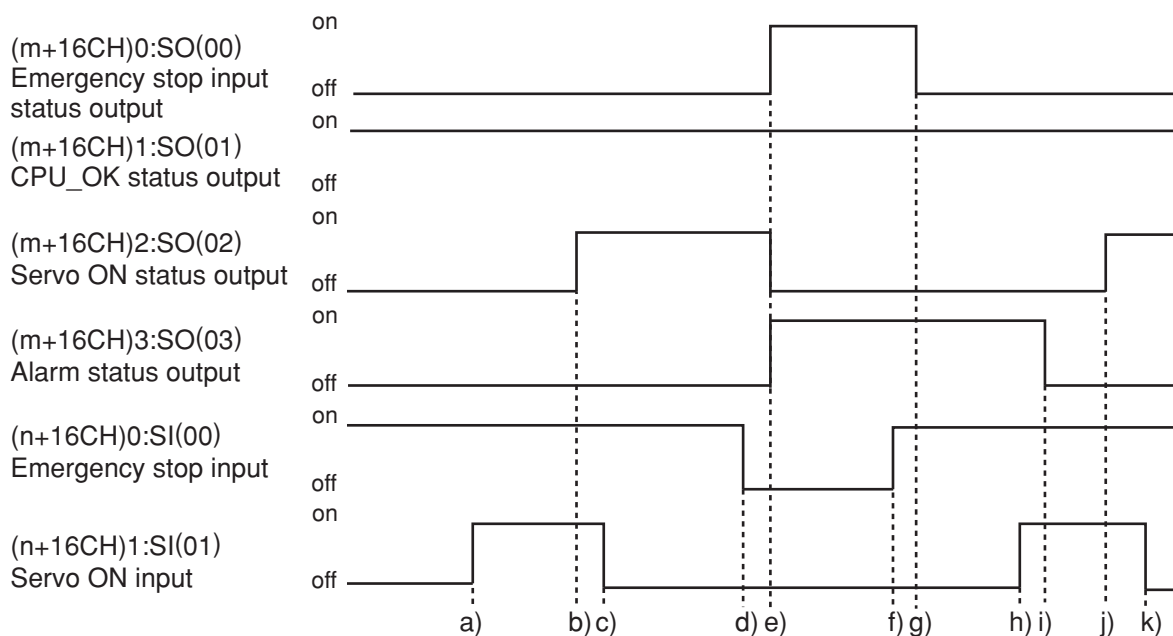

CAUTION

- This explanation uses the channel numbers which are available when the IO size is set to "Large". Note that the channel numbers differ when the IO size is set to "Small".
- Provide an interval of 100ms or more when turning the dedicated input from the master module to the controller ON and OFF. If the interval is too short, the dedicated input may not be recognized. (This also applies to the interval for the same dedicated inputs or differing dedicated inputs.)
- Use this also if there is a dedicated output in respect to the dedicated input from the master module to the controller.

Initial servo ON process after power ON

- Servo ON input ON is input
- If not in the emergency stop state, output servo ON status ON is output
- After confirming that servo ON status output is ON, servo ON input OFF is input

Shift to emergency stop

- Emergency stop input OFF is input
- Emergency stop input status ON and alarm status output ON are output
Servo ON status output OFF is output

3. Dedicated input/output signal timing chart

Servo ON process from emergency stop status

- f) Emergency stop input ON is input
- g) Emergency stop input status output OFF is output
- h) Servo ON input ON is input
- i) Alarm status output OFF is output
- j) Servo ON status output ON is output
- k) After confirming that servo ON status output is ON, servo ON input OFF is input

* The servo is OFF when the controller power is turned ON.

* When SAFE mode is enabled, dedicated inputs other than SI (00) and SI (11) might be disabled depending on service mode parameter setting unless service mode input signal is set to ON with SI (02) in the DeviceNet system.

3.2 AUTO mode changeover, program reset and program execution

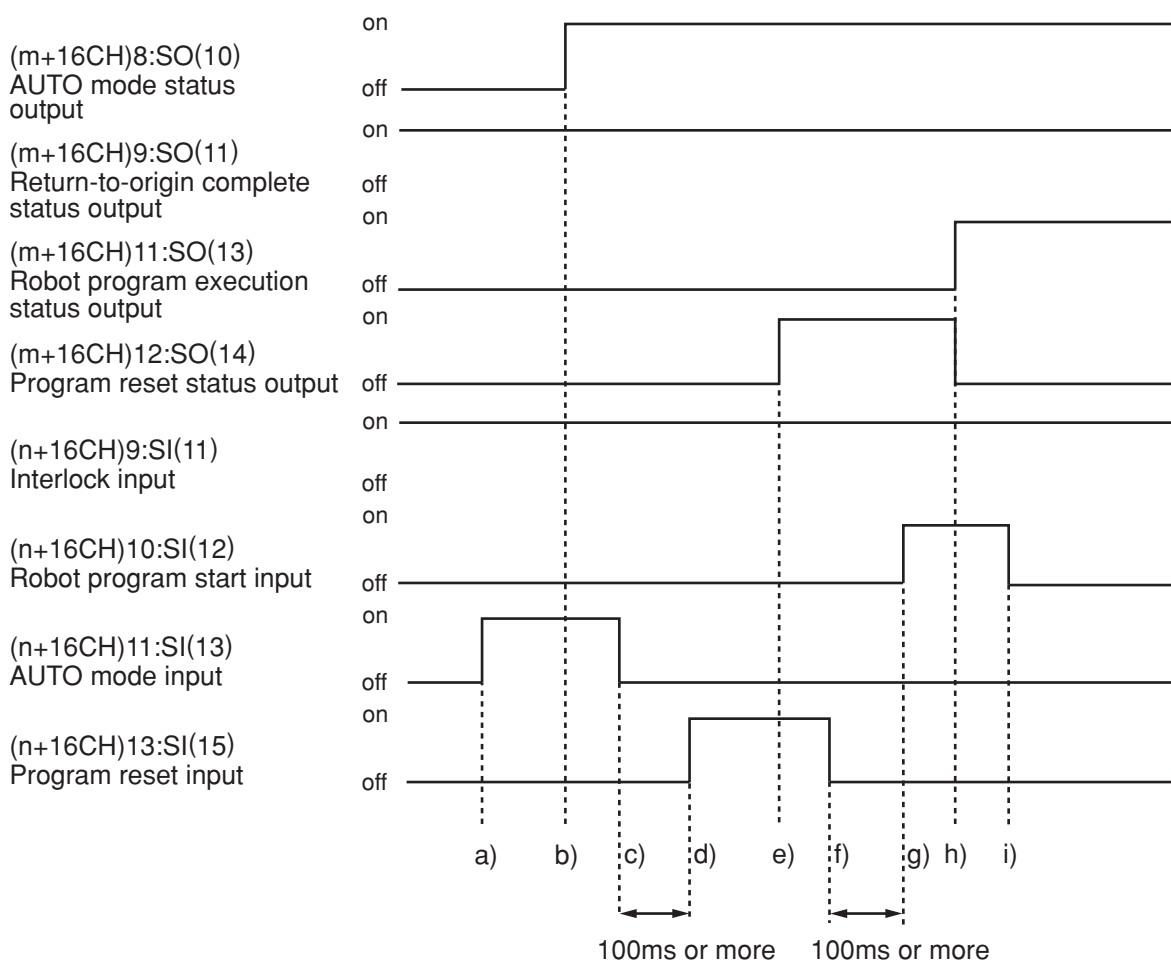

**CAUTION**

- This explanation uses the channel numbers which are available when the IO size is set to "Large". Note that the channel numbers differ when the IO size is set to "Small".
- Provide an interval of 100ms or more when turning the dedicated input from the master module to the controller ON and OFF. If the interval is too short, the dedicated input may not be recognized. (This also applies to the interval for the same dedicated inputs or differing dedicated inputs.)
- Use this also if there is a dedicated output in respect to the dedicated input from the master module to the controller.

AUTO mode changeover process

- a) AUTO mode input ON is input
- b) AUTO mode status output ON is output
- c) After confirming that the AUTO mode status output is ON, the AUTO mode input OFF is input

Program reset process

- d) Program reset input ON is input
- e) Program reset status output ON is output
- f) After confirming that the program reset status output is ON, the program reset input OFF is input

Program execution process

- g) Robot program start input ON is input
 - h) Program reset status output OFF is output
Robot program execution status output ON is output
 - i) After confirming that the robot program execution status output is ON, the robot program start input OFF is input
- * The program cannot be executed if the emergency stop input and interlock input are OFF.
 - * If the return-to-origin complete status output is not ON, execution of the program may not be possible depending on the execution level setting value.
 - * When SAFE mode is enabled, dedicated inputs other than SI (00) and SI (11) might be disabled depending on service mode parameter setting unless service mode input signal is set to ON with SI (02) in the DeviceNet system.

3.3 Stopping with program interlock

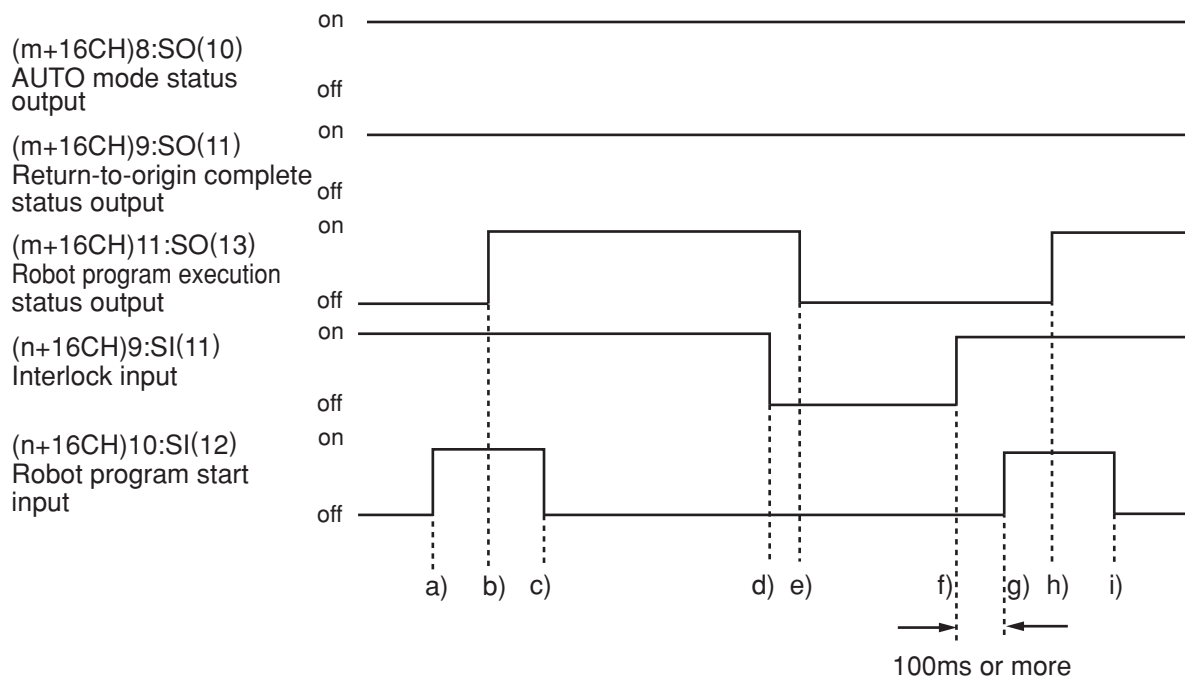
**CAUTION**

- This explanation uses the channel numbers which are available when the IO size is set to "Large". Note that the channel numbers differ when the IO size is set to "Small".
- Provide an interval of 100ms or more when turning the dedicated input from the master module to the controller ON and OFF. If the interval is too short, the dedicated input may not be recognized. (This also applies to the interval for the same dedicated inputs or differing dedicated inputs.)
- Use this also if there is a dedicated output in respect to the dedicated input from the master module to the controller.

Program execution process

- Robot program start input ON is input
- Robot program execution status output ON is output
- After confirming that the robot program execution status output is ON, the start input OFF is input

Program stop process using interlock input

- Interlock input OFF is input
- Robot program execution status output OFF is output

Program execution after stopping program with interlock input

- Interlock input ON is input
- Robot program start input ON is input
- Robot program execution status output ON is output
- After confirming that the robot program execution status output is ON, the start input OFF is input

3. Dedicated input/output signal timing chart

- * The program also stops when emergency stop input OFF is input. At this point, emergency stop input status ON and alarm status output ON are output, and servo ON status output OFF is output. To re-execute the program, servo ON process is required.
- * When SAFE mode is enabled, dedicated inputs other than SI (00) and SI (11) might be disabled depending on service mode parameter setting unless service mode input signal is set to ON with SI (02) in the DeviceNet system.

4. Sample program

An example for the following type of hardware configuration has been prepared for this section.

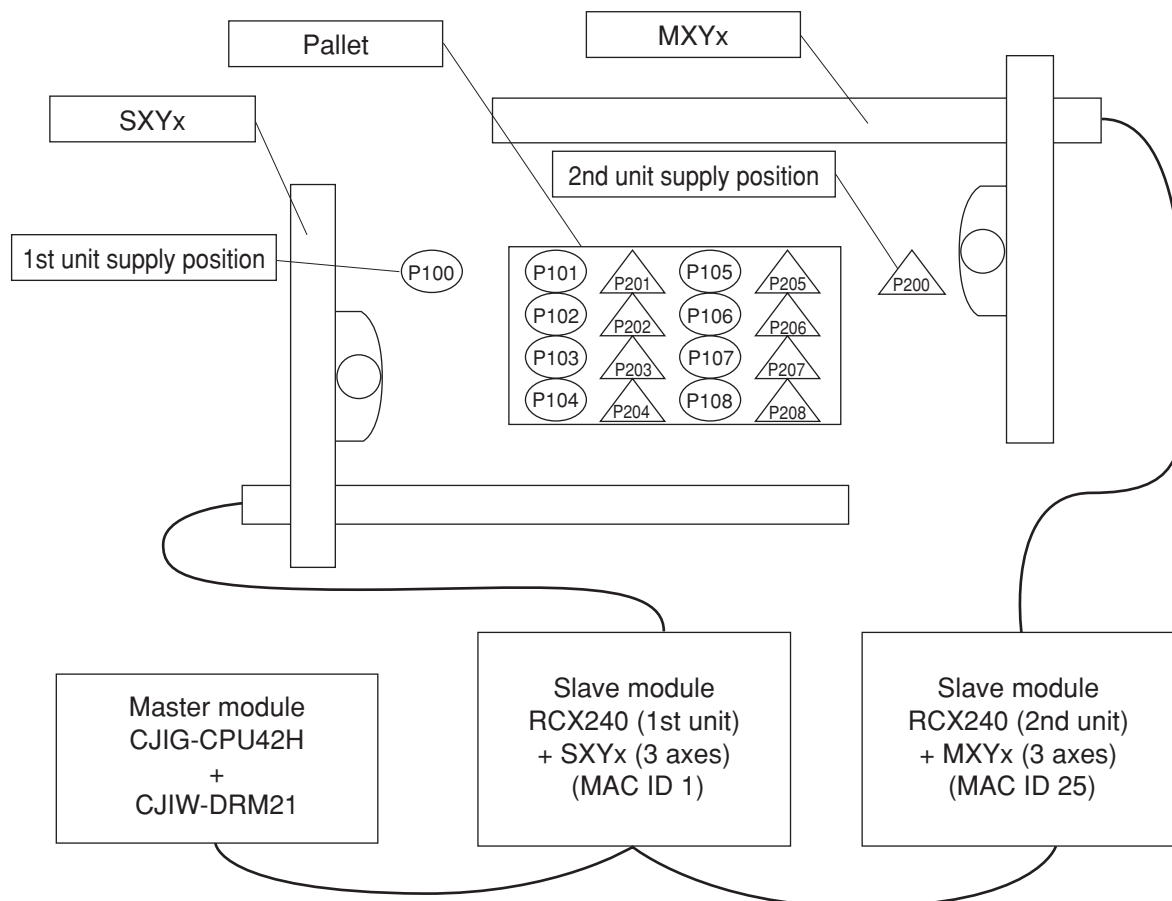

[Details of sample]

- Pick & place work is carried out using the PLC and RCX240 + SXYx (3 axes), RCX240+MXYx (3 axes).
 - The workpieces supplied to each robot are arranged on one pallet.
 - The workpiece is supplied at a rate faster than the robot operation.
 - The two robots will interfere above the pallet, so data is exchanged to prevent interference.
 - When handling the workpiece, the robot moves at a low speed.
 - The robot controller directly exchanges the pallet.
- * Refer to the robot programming manual for details on the robot program language.
- * The PLC circuit is a simple circuit that executes the selected robot program when emergency stop is canceled.



CAUTION

Explanations are given based on the channels for the OMRON master module. Refer to the respective manuals when using other master module brands.

[Robot program data assignment]*** Variables used**

1st unit : A : Point No. in pallet
 2nd unit : B : Point No. in pallet

*** Points used**

1st unit : P100 : Point above workpiece supply
 P101 : 1st point above pallet
 : :
 P108 : 8th point above pallet
 P121 : Z axis position point for workpiece supply
 P122 : Z axis position point on pallet
 2nd unit : P200 : Point above workpiece supply
 P201 : 1st point above pallet
 : :
 P208 : 8th point above pallet
 P221 : Z axis position point for workpiece supply
 P222 : Z axis position point on pallet

*** Bit data used**

1st unit : SI (40) : Point No. reception complete input
 SI (41) : Movement complete response standby input
 SI (42) : Movement complete standby input
 SO (23) to SO (20) : Point No. setting output group
 SO (40) : Point No. setting complete output
 SO (41) : Movement complete output
 SO (42) : Movement complete response output
 DI (47) : Pallet change complete input
 DO (40) : Chuck hand open close (0: Close, 1: Open)
 DO (47) : Pallet exchange command output
 2nd unit : SI (23) to SI (20) : Point No. setting input group
 SI (40) : Point No. transmission complete input
 SI (41) : Movement complete standby input
 SI (42) : Movement complete response standby input
 SO (40) : Point No. setting reception complete output
 SO (41) : Movement complete response output
 SO (42) : Movement complete output
 DO (40) : Chuck hand open/close (0: Close, 1: Open)

4. Sample program

[PLC data assignment]

In this example, the first unit MAC ID is designated as "1" and the second unit MAC ID as "25". The PLC output channel is allocated "3200" while the input channel is allocated "3300".

MAC ID1	(1510CH)	0	Unit error	} : Word information		
		:				
		15				
	:					
	(1512CH)	0			} : Bit information	
		:				
		15	IO data communication status			
	:					
	(3201CH)	0	1st unit's SIW(0)			} : Bit information
		:				
		15				
	(3202CH)	0	1st unit's SIW(1)			
		:				
		15				
	:					
(3216CH)	0	1st unit's SIW(15)				
	:					
	15					
(3217CH)	0	1st unit's SI(00) : Emergency stop input				
	1	1st unit's SI(01) : Servo ON input				
	2	1st unit's SI(02) : Service mode input				
	3	1st unit's SI(03) :				
	4	1st unit's SI(04) :				
	5	1st unit's SI(05) : IO command execution trigger input				
	6	1st unit's SI(06) :				
	7	1st unit's SI(07) :				
	8	1st unit's SI(10) : Sequence control input				
	9	1st unit's SI(11) : Interlock input				
	10	1st unit's SI(12) : Robot program start input				
	11	1st unit's SI(13) : AUTO mode input				
	12	1st unit's SI(14) :				
	13	1st unit's SI(15) : Program reset input				
	14	1st unit's SI(16) : MANUAL mode input				
	15	1st unit's SI(17) : Absolute reset input				
	(3218CH)	0	1st unit's SI(20) : General-purpose input			
1		1st unit's SI(21) : General-purpose input				
2		1st unit's SI(22) : General-purpose input				
3		1st unit's SI(23) : General-purpose input				
4		1st unit's SI(24) : General-purpose input				
5		1st unit's SI(25) : General-purpose input				
6		1st unit's SI(26) : General-purpose input				
7		1st unit's SI(27) : General-purpose input				
8		1st unit's SI(30) : General-purpose input				
9		1st unit's SI(31) : General-purpose input				
10		1st unit's SI(32) : General-purpose input				
11		1st unit's SI(33) : General-purpose input				
12		1st unit's SI(34) : General-purpose input				
13		1st unit's SI(35) : General-purpose input				
14		1st unit's SI(36) : General-purpose input				
15		1st unit's SI(37) : General-purpose input				
:						
(3223CH)	0	1st unit's SI(140) : General-purpose input				
	1	1st unit's SI(141) : General-purpose input				
	2	1st unit's SI(142) : General-purpose input				
	3	1st unit's SI(143) : General-purpose input				
	4	1st unit's SI(144) : General-purpose input				
	5	1st unit's SI(145) : General-purpose input				
	6	1st unit's SI(146) : General-purpose input				
	7	1st unit's SI(147) : General-purpose input				
	8	1st unit's SI(150) : General-purpose input				
	9	1st unit's SI(151) : General-purpose input				
	10	1st unit's SI(152) : General-purpose input				
	11	1st unit's SI(153) : General-purpose input				
	12	1st unit's SI(154) : General-purpose input				
	13	1st unit's SI(155) : General-purpose input				
	14	1st unit's SI(156) : General-purpose input				
	15	1st unit's SI(157) : General-purpose input				
	(3224CH)	0	1st unit reservation area			
:						
15						

MAC ID25

(3225CH)	0	2nd unit's SIW(0)
	:	
	15	
(3226CH)	0	2nd unit's SIW(1)
	:	
	15	
:		
(3240CH)	0	2nd unit's SIW(15)
	:	
	15	
(3241CH)	0	2nd unit's SI(00) : Emergency stop input
	1	2nd unit's SI(01) : Servo ON input
	2	2nd unit's SI(02) : Service mode input
	3	2nd unit's SI(03) :
	4	2nd unit's SI(04) :
	5	2nd unit's SI(05) : IO command execution trigger input
	6	2nd unit's SI(06) :
	7	2nd unit's SI(07) :
	8	2nd unit's SI(10) : Sequence control input
	9	2nd unit's SI(11) : Interlock input
	10	2nd unit's SI(12) : Robot program start input
	11	2nd unit's SI(13) : AUTO mode input
	12	2nd unit's SI(14) :
	13	2nd unit's SI(15) : Program reset input
	14	2nd unit's SI(16) : MANUAL mode input
	15	2nd unit's SI(17) : Absolute reset input
(3242CH)	0	2nd unit's SI(20) : General-purpose input
	1	2nd unit's SI(21) : General-purpose input
	2	2nd unit's SI(22) : General-purpose input
	3	2nd unit's SI(23) : General-purpose input
	4	2nd unit's SI(24) : General-purpose input
	5	2nd unit's SI(25) : General-purpose input
	6	2nd unit's SI(26) : General-purpose input
	7	2nd unit's SI(27) : General-purpose input
	8	2nd unit's SI(30) : General-purpose input
	9	2nd unit's SI(31) : General-purpose input
	10	2nd unit's SI(32) : General-purpose input
	11	2nd unit's SI(33) : General-purpose input
	12	2nd unit's SI(34) : General-purpose input
	13	2nd unit's SI(35) : General-purpose input
	14	2nd unit's SI(36) : General-purpose input
	15	2nd unit's SI(37) : General-purpose input
:		
(3247CH)	0	2nd unit's SI(140) : General-purpose input
	1	2nd unit's SI(141) : General-purpose input
	2	2nd unit's SI(142) : General-purpose input
	3	2nd unit's SI(143) : General-purpose input
	4	2nd unit's SI(144) : General-purpose input
	5	2nd unit's SI(145) : General-purpose input
	6	2nd unit's SI(146) : General-purpose input
	7	2nd unit's SI(147) : General-purpose input
	8	2nd unit's SI(150) : General-purpose input
	9	2nd unit's SI(151) : General-purpose input
	10	2nd unit's SI(152) : General-purpose input
	11	2nd unit's SI(153) : General-purpose input
	12	2nd unit's SI(154) : General-purpose input
	13	2nd unit's SI(155) : General-purpose input
	14	2nd unit's SI(156) : General-purpose input
	15	2nd unit's SI(157) : General-purpose input
(3248CH)	0	2nd unit reservation area
	:	
	15	

: Word information

: Bit information

4. Sample program

MAC ID1	(3301CH)	0	1st unit's SOW(0)	} : Word information	
		:			
		15			
(3302CH)		0	1st unit's SOW(1)		
		:			
		15			
:					
(3316CH)		0	1st unit's SOW(15)		
		:			
		15			
(3317CH)		0	1st unit's SO(00) : Emergency stop input status output		} : Bit information
		1	1st unit's SO(01) : CPU_OK status output		
		2	1st unit's SO(02) : Servo ON status output		
		3	1st unit's SO(03) : Alarm status output		
		4	1st unit's SO(04) :		
		5	1st unit's SO(05) :		
		6	1st unit's SO(06) :		
		7	1st unit's SO(07) :		
		8	1st unit's SO(10) : AUTO mode status output		
		9	1st unit's SO(11) : Return-to-origin complete status output		
		10	1st unit's SO(12) : Sequence program execution status output		
		11	1st unit's SO(13) : Robot program execution status output		
		12	1st unit's SO(14) : Program reset status output		
		13	1st unit's SO(15) :		
		14	1st unit's SO(16) : IO command execution judgment output		
		15	1st unit's SO(17) : Output during IO command execution		
(3318CH)		0	1st unit's SO(20) : General-purpose output		
		1	1st unit's SO(21) : General-purpose output		
		2	1st unit's SO(22) : General-purpose output		
		3	1st unit's SO(23) : General-purpose output		
		4	1st unit's SO(24) : General-purpose output		
		5	1st unit's SO(25) : General-purpose output		
		6	1st unit's SO(26) : General-purpose output		
		7	1st unit's SO(27) : General-purpose output		
		8	1st unit's SO(30) : General-purpose output		
		9	1st unit's SO(31) : General-purpose output		
		10	1st unit's SO(32) : General-purpose output		
		11	1st unit's SO(33) : General-purpose output		
		12	1st unit's SO(34) : General-purpose output		
		13	1st unit's SO(35) : General-purpose output		
		14	1st unit's SO(36) : General-purpose output		
		15	1st unit's SO(37) : General-purpose output		
:					
(3323CH)		0	1st unit's SO(140) : General-purpose output		
		1	1st unit's SO(141) : General-purpose output		
		2	1st unit's SO(142) : General-purpose output		
		3	1st unit's SO(143) : General-purpose output		
		4	1st unit's SO(144) : General-purpose output		
		5	1st unit's SO(145) : General-purpose output		
		6	1st unit's SO(146) : General-purpose output		
		7	1st unit's SO(147) : General-purpose output		
		8	1st unit's SO(150) : General-purpose output		
		9	1st unit's SO(151) : General-purpose output		
		10	1st unit's SO(152) : General-purpose output		
		11	1st unit's SO(153) : General-purpose output		
		12	1st unit's SO(154) : General-purpose output		
		13	1st unit's SO(155) : General-purpose output		
		14	1st unit's SO(156) : General-purpose output		
		15	1st unit's SO(157) : General-purpose output		
(3324CH)		0	1st unit reservation area		
		:			
		15			

MAC ID25

(3325CH)	0	2nd unit's SOW(0)
	:	
	15	
(3326CH)	0	2nd unit's SOW(1)
	:	
	15	
:		
(3340CH)	0	2nd unit's SOW(15)
	:	
	15	
(3341CH)	0	2nd unit's SO(00) : Emergency stop input status output
	1	2nd unit's SO(01) : CPU_OK status output
	2	2nd unit's SO(02) : Servo ON status output
	3	2nd unit's SO(03) : Alarm status output
	4	2nd unit's SO(04) :
	5	2nd unit's SO(05) :
	6	2nd unit's SO(06) :
	7	2nd unit's SO(07) :
	8	2nd unit's SO(10) : AUTO mode status output
	9	2nd unit's SO(11) : Return-to-origin complete status output
	10	2nd unit's SO(12) : Sequence program execution status output
	11	2nd unit's SO(13) : Robot program execution status output
	12	2nd unit's SO(14) : Program reset status output
	13	2nd unit's SO(15) :
	14	2nd unit's SO(16) : IO command execution judgment output
15	2nd unit's SO(17) : Output during IO command execution	
(3342CH)	0	2nd unit's SO(20) : General-purpose output
	1	2nd unit's SO(21) : General-purpose output
	2	2nd unit's SO(22) : General-purpose output
	3	2nd unit's SO(23) : General-purpose output
	4	2nd unit's SO(24) : General-purpose output
	5	2nd unit's SO(25) : General-purpose output
	6	2nd unit's SO(26) : General-purpose output
	7	2nd unit's SO(27) : General-purpose output
	8	2nd unit's SO(30) : General-purpose output
	9	2nd unit's SO(31) : General-purpose output
	10	2nd unit's SO(32) : General-purpose output
	11	2nd unit's SO(33) : General-purpose output
	12	2nd unit's SO(34) : General-purpose output
	13	2nd unit's SO(35) : General-purpose output
	14	2nd unit's SO(36) : General-purpose output
15	2nd unit's SO(37) : General-purpose output	
:		
(3347CH)	0	2nd unit's SO(140) : General-purpose output
	1	2nd unit's SO(141) : General-purpose output
	2	2nd unit's SO(142) : General-purpose output
	3	2nd unit's SO(143) : General-purpose output
	4	2nd unit's SO(144) : General-purpose output
	5	2nd unit's SO(145) : General-purpose output
	6	2nd unit's SO(146) : General-purpose output
	7	2nd unit's SO(147) : General-purpose output
	8	2nd unit's SO(150) : General-purpose output
	9	2nd unit's SO(151) : General-purpose output
	10	2nd unit's SO(152) : General-purpose output
	11	2nd unit's SO(153) : General-purpose output
	12	2nd unit's SO(154) : General-purpose output
	13	2nd unit's SO(155) : General-purpose output
	14	2nd unit's SO(156) : General-purpose output
15	2nd unit's SO(157) : General-purpose output	
(3348CH)	0	2nd unit reservation area
	:	
	15	

: Word information

: Bit information

4. Sample program

[Robot program]

1st unit's RCX240

```
'INIT ROUTINE
  RESET SO2()
  RESET SO4()
  RESET DO4()
  A=101
'MAIN ROUTINE
  MOVE P,P100,Z=0
  GOSUB *PICK
*ST1:
  MOVE P,P[A],Z=0
  GOSUB *PLACE
  MOVE P,P100,Z=0
  SO(41)=1
  WAIT SI(41)=1
  SO(41)=0
  WAIT SI(41)=0
  SO(23,22,21,20)=A-100
  SO(40)=1
  WAIT SI(40)=1
  SO(40)=0
  WAIT SI(40)=0
  SO(23,22,21,20)=0
  GOSUB *PICK
  WAIT SI(42)=1
  SO(42)=1
  WAIT SI(42)=0
  SO(42)=0
  A=A+1
  IF A>108 THEN
    A=101
    DO(47)=1
    WAIT DI(47)=1
    DO(47)=0
  ENDIF
  GOTO *ST1
  HALT
'SUB ROUTINE FOR PICK
*PICK:
  DO(40)=1
  DRIVE(3,P121),S=20
  WAIT ARM(3)
  DO(40)=0
  DELAY 500
  RETURN
'SUB ROUTINE FOR PLACE
*PLACE:
  DRIVE(3,P122),S=20
  WAIT ARM(3)
  DO(40)=1
  DELAY 500
  RETURN
```

2nd unit's RCX240

```
'INIT ROUTINE
  RESET SO2()
  RESET SO4()
  RESET DO4()
  B=201
'MAIN ROUTINE
  MOVE P,P200,Z=0
  GOSUB *PICK
*ST2:
  WAIT SI(41)=1
  SO(41)=1
  WAIT SI(41)=0
  SO(41)=0
  WAIT SI(40)=1
  B=SI(23,22,21,20)
  SO(40)=1
  WAIT SI(40)=0
  SO(40)=0
  B=B+200
  MOVE P,P[B],Z=0
  GOSUB *PLACE
  MOVE P,P200,Z=0
  SO(42)=1
  WAIT SI(42)=1
  SO(42)=0
  WAIT SI(42)=0
  GOSUB *PICK
  GOTO *ST2
  HALT
'SUB ROUTINE FOR PICK
*PICK:
  DO(40)=1
  DRIVE(3,P221),S=20
  WAIT ARM(3)
  DO(40)=0
  DELAY 500
  RETURN
'SUB ROUTINE FOR PLACE
*PLACE:
  DRIVE(3,P222),S=20
  WAIT ARM(3)
  DO(40)=1
  DELAY 500
  RETURN
```

[PLC program]

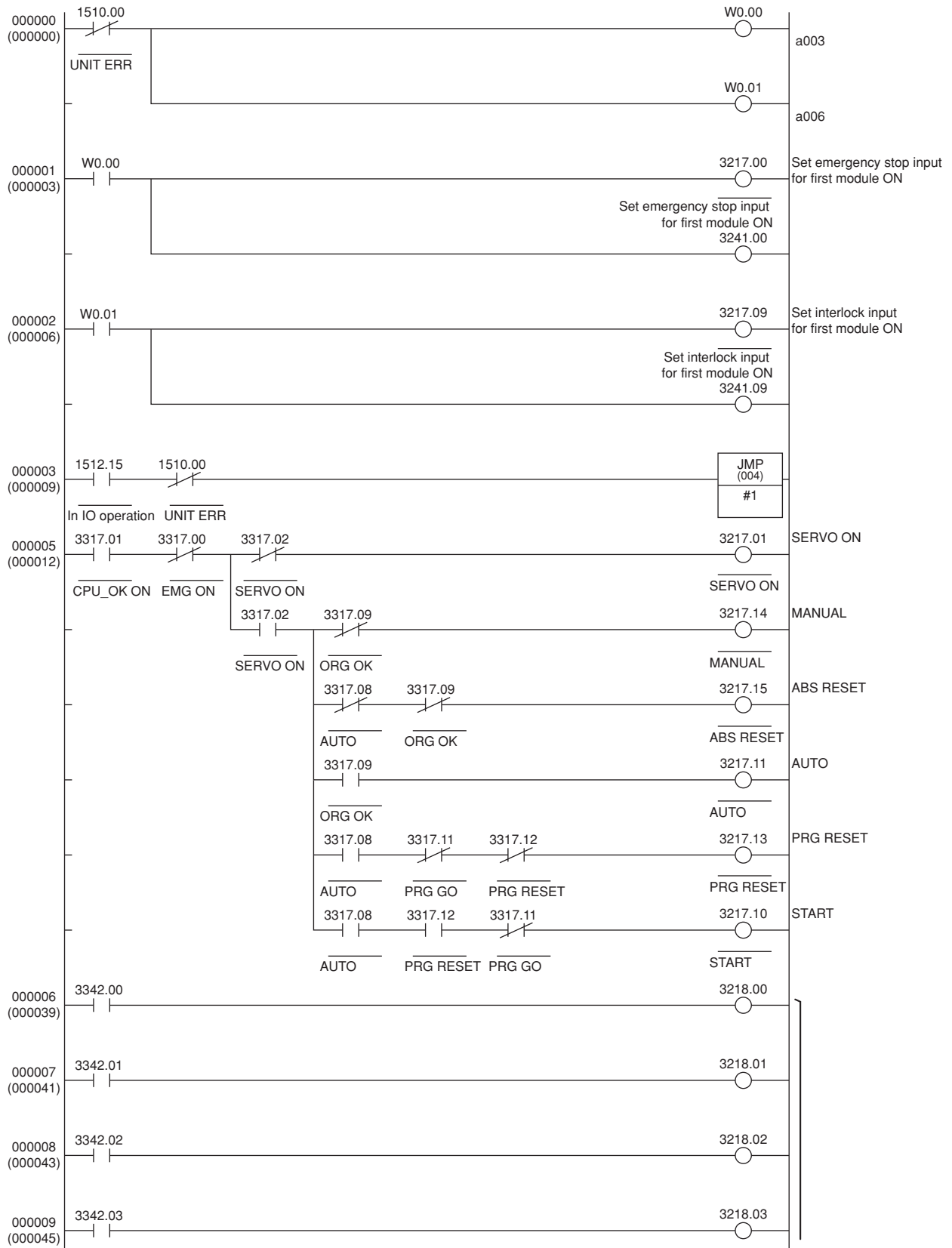

4. Sample program

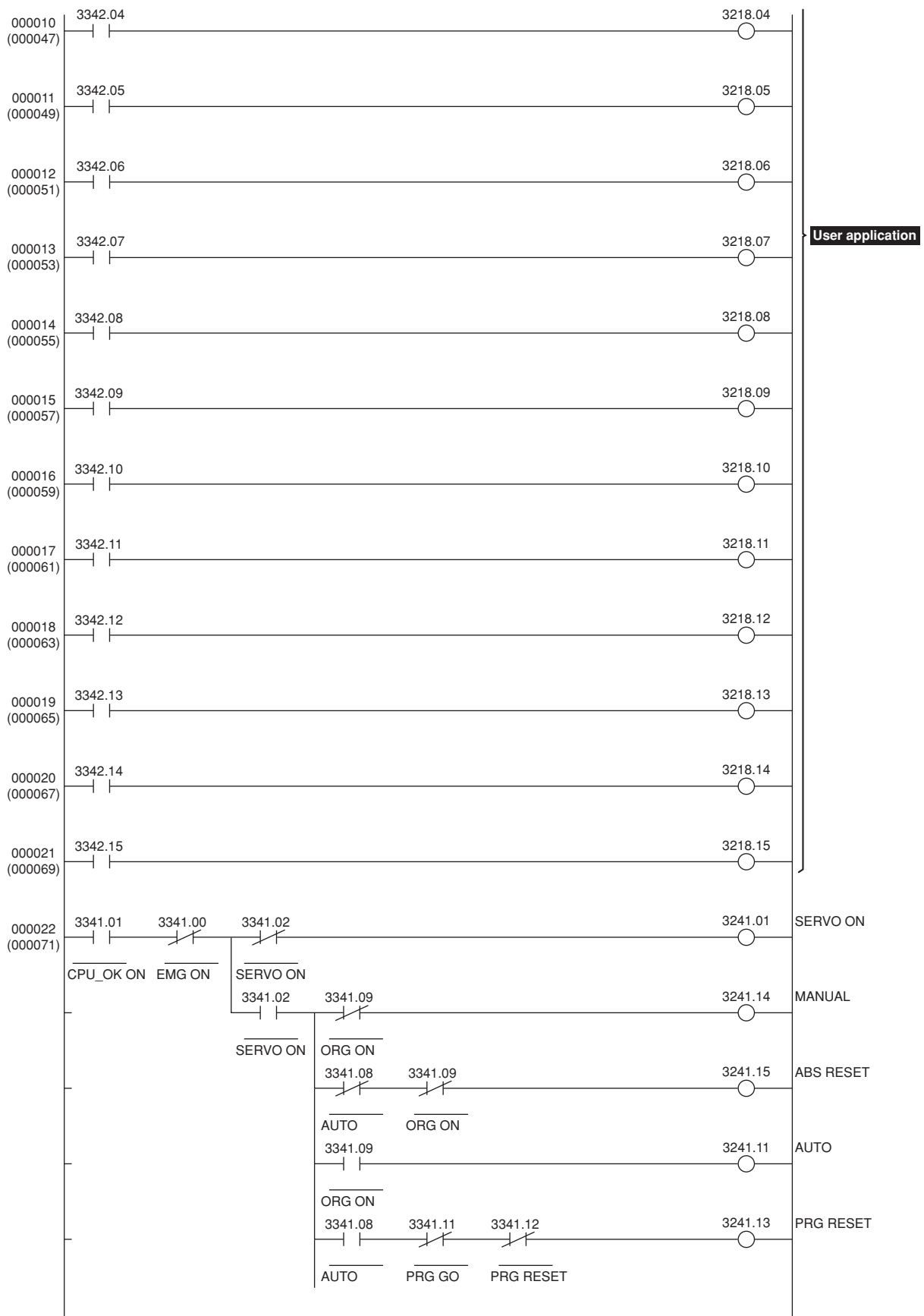

4. Sample program

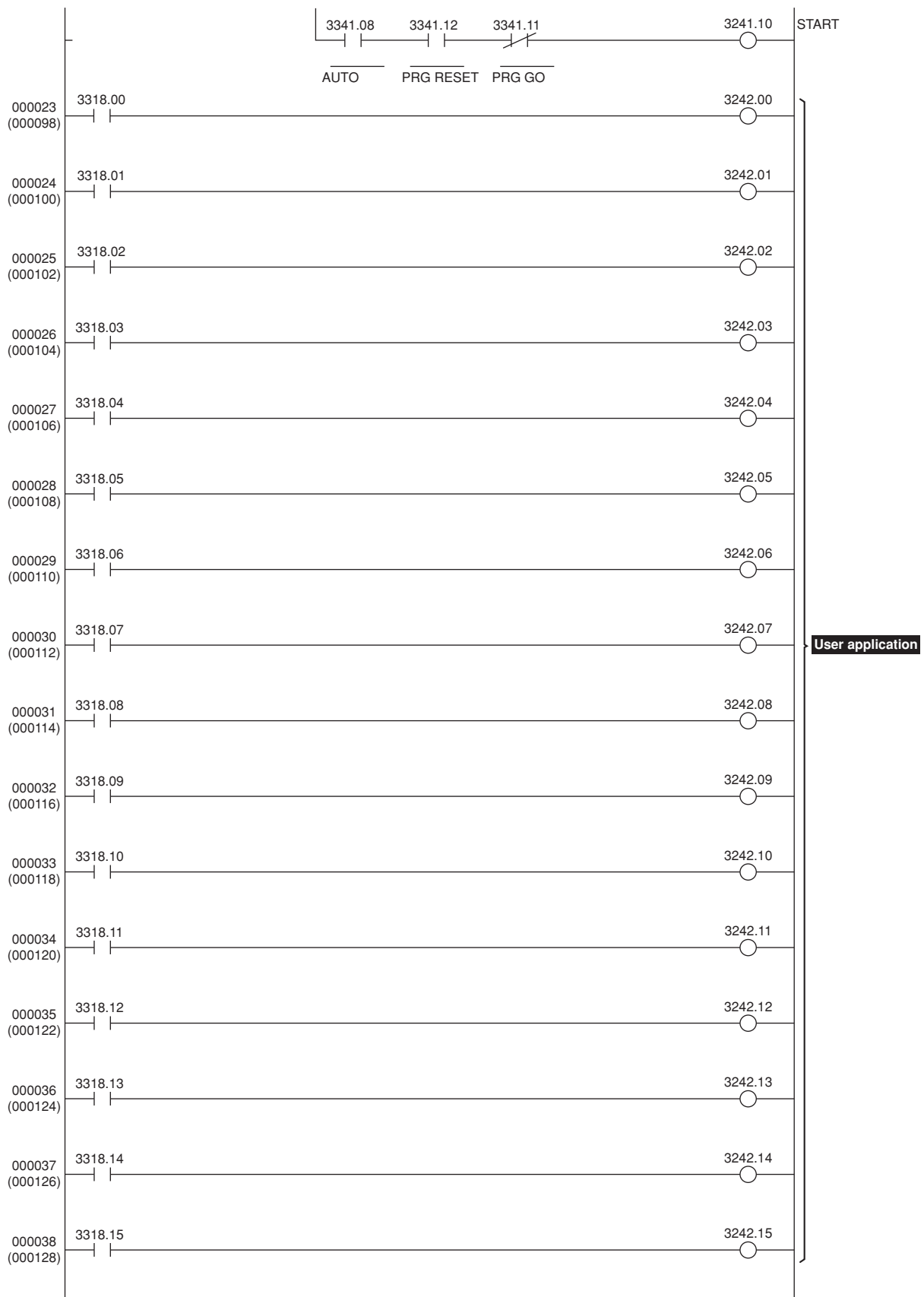

4. Sample program

000039
(000130)

JME
(005)

#1

000040
(000131)

END
(001)

5. DeviceNet compatible module specifications

Model	DeviceNet Unit			
Spec. Item				
Controller models	RCX series controller			
Conforms to DeviceNet Specification	Volume 1 Release 2.0 Volume 2 Release 2.0			
Device Profile Name	Generic Device (Device Type Number 0)			
Number of channels used *1)	When IO size is "Large" : Input/output 24 channels each When IO size is "Small" : Input/output 2 channels each			
MAC ID setting	0 to 63 (Set with rotary switch on board)			
Transmission speed setting	500K/250K/125Kbps (Set with rotary switch on board)			
Communication data *2)	Predefined Master/Slave Connection Set : Group Only 2 server Dynamic Connections Supported (UCMM) : No Fragmented Explicit Messaging Implemented : Yes			
DeviceNet I/O points *3) (48 bytes or 4 bytes selectable)	When IO size is "Large"	Input (Total 48 bytes)	byte 0-3	Dedicated word input : 2 words
			byte 4-31	General purpose word input : 14 words
		Output (Total 48 bytes)	byte 32-33	Dedicated bit input : 16 points
			byte 34-47	General-purpose bit input : 96 points
	When IO size is "Small"	Input (Total 4 bytes)	byte 0-3	Dedicated word input : 2 words
			byte 4-31	General purpose word input : 14 words
When IO size is "Small"	Output (Total 4 bytes)	byte 32-33	Dedicated bit output : 16 points	
		byte 34-47	General-purpose bit output : 96 points	
Parallel external I/O	The master module and up to four ports can be controlled regardless of the robot program by using the pseudoserialization function.			
Network Topology		Maximum Trunk Distance *4)	Maximum Drop Length	Cumulative Drop Length
	500Kbps	100m	6m or less	39m or less
	250Kbps	250m	6m or less	78m or less
	125Kbps	500m	6m or less	156m or less
Monitor LED	MS (Module Status), NS (Network Status)			

*1) One channel uses 16 bits (2 bytes).

*2) The explicit message function is not supported by the controller.

*3) Controller's I/O update intervals are 10ms at shortest, but actual I/O update intervals change depending on the update time for the master station.

*4) When thick cables are used. Distance will be short if a thin cable is used or thin and thick cables are used.



CAUTION

- IO size setting is only supported by Ver. 8.63 onwards of the RCX14x controllers and Ver. 9.09 onwards of the RCX22x controllers. The number of channels used and the number of DeviceNet I/O points for earlier version controllers are the same as those of the "Large" IO size setting. The IO size can be set by option board parameter. Refer to section 6 of chapter 2 for more details.
- For the names and description of word and bit input/output signals, refer to the tables shown in "1. Profile" and "2. Details of input/output signals" in this chapter.
- The specifications and appearance are subject to change without prior notice.

6. DeviceNet specifications

■ General Device Data

Conforms to DeviceNet Specification	Volume 1 Release2.0 Volume 2 Release2.0
Vendor Name	YAMAHA MOTOR CO.,LTD.(Vendor ID 636)
Device Profile Name	Generic Device(Device Type Number 0)
Product Code	2
Product Revision	1.1

■ DeviceNet Physical Conformance Data

Network Power Consumption(Max)	55mA@DC11V
Connector Style	Open-Pluggable
Isolated Physical Layer	Yes
LEDs Supported	Module, Network
MAC ID Setting	Rotary Switch
Default MAC ID	1
Communication Rate Setting	Rotary Switch
Communication Rates Supported	125Kbps, 250Kbps, 500Kbps

■ DeviceNet Communication Data

Predefined Master/Slave Connection Set	Group 2 Only Server
Dynamic Connections Supported (UCMM)	No
Fragmented Explicit Messaging Implemented	Yes

DeviceNet Required Object Implementation

● Identity Object(0x01)

Object Class

Attributes	None Supported
Services	None Supported

Object Instance

Attributes	ID	Description	Get	Set	Value Limit
	1	Vender	○	×	636
	2	Product type	○	×	0
	3	Product code	○	×	2
	4	Revision	○	×	1.1
	5	Status (bits supported)	○	×	bit0 only
	6	Serial number	○	×	each unit
	7	Product name	○	×	YAMAHA ROBOT RCX
	8	State	×	×	
	9	Configuration Consistency Value	×	×	
	10	Heartbeat Interval	×	×	
Services	DeviceNet Services		Parameter Options		
	05H	Reset	none		
	0EH	Get_Attribute_Single	none		

● Message Router Object(0x02)

Object Class

Attributes	None Supported
Services	None Supported

Object Instance

Attributes	None Supported
Services	None Supported

Vendor Specific Additions

No

● DeviceNet Object (0x03)

Object Class

Attributes	ID	Description	Get	Set	Value Limit
		1	Revision	○	×
Services	DeviceNet Services		Parameter Options		
	0EH	Get_Attribute_Single	none		

Object Instance

Attributes	ID	Description	Get	Set	Value Limit
	1	MAC ID	○	×	
	2	Baud rate	○	×	
	3	BOI	○	×	00H
	4	Bus-off counter	×	×	
	5	Allocation information	○	×	
	6	MAC ID switch changed	×	×	
	7	Baud rate switch changed	×	×	
	8	MAC ID switch value	×	×	
	9	Baud rate switch value	×	×	
Services	DeviceNet Services		Parameter Options		
	0EH	Get_Attribute_Single	none		
	4BH	Allocate_Master/Slave_Connection_Set	none		
	4CH	Release_Master/Slave_Connection_Set	none		

● Assembly Object (0x04)

Object Class

Attributes	None Supported
Services	None Supported

Object Instance

Section	Description		Information		
		Instance Type		Static I/O Max Instance:1	
Attributes	ID	Description	Get	Set	Value Limit
	1	Number of Members in List	×	×	
	2	Member List	×	×	
	3	Data	○	×	
Services	DeviceNet Services		Parameter Options		
	0EH	Get_Attribute_Single	none		

● Connection Object(0x05)

Object Class

Attributes	None Supported
Services	None Supported
Total Active Connections Possible	1

Object Instance 1

Section	Description		Information		
	Instance Type		Explicit Message Max Instance:1		
	Production Trigger		Cyclic		
	Transport Type		Server		
	Transport Class		3		
Attributes	ID	Description	Get	Set	Value Limit
	1	State	○	×	
	2	Instance type	○	×	00H
	3	Transport class trigger	○	×	83H
	4	Produced connection ID	○	×	
	5	Consumed connection ID	○	×	
	6	Initial comm. Characteristics	○	×	21H
	7	Produced connection size	○	×	11H
	8	Consumed connection size	○	×	11H
	9	Expected packet rate	○	○	
	12	Watchdog time-out action	○	○	01 or 03
	13	Produced connection path length	○	×	00
	14	Produced connection path	○	×	
	15	Consumed connection path length	○	×	00
16	Consumed connection path	○	×		
17	Production inhibit time	○	×	00	
Services	DeviceNet Services		Parameter Options		
	05H	Reset	none		
	0EH	Get_Attribute_Single	none		
	10H	Set_Attribute_Single	none		

Object Instance 2

Section	Description		Information		
	Instance Type		Polled I/O Max Instance:1		
	Production Trigger		Cyclic		
	Transport Type		Server		
	Transport Class		2		
Attributes	ID	Description	Get	Set	Value Limit
	1	State	○	×	
	2	Instance type	○	×	01H
	3	Transport class trigger	○	×	82H
	4	Produced connection ID	○	×	
	5	Consumed connection ID	○	×	
	6	Initial comm. Characteristics	○	×	01H
	7	Produced connection size	○	×	4
	8	Consumed connection size	○	×	4
	9	Expected packet rate	○	○	
	12	Watchdog time-out action	○	×	00
	13	Produced connection path length	○	×	6
	14	Produced connection path	○	×	20_04_24_01_30_03
	15	Consumed connection path length	○	×	6
16	Consumed connection path	○	×	20_04_24_01_30_03	
17	Production inhibit time	○	×	00	
Services	DeviceNet Services		Parameter Options		
	05H	Reset	none		
	0EH	Get_Attribute_Single	none		
	10H	Set_Attribute_Single	none		

Object Instance 3

Section	Description		Information		
	Instance Type		Bit Strobed I/O Max Instance:1		
	Production Trigger		Cyclic		
	Transport Type		Server		
	Transport Class		2		
Attributes	ID	Description	Get	Set	Value Limit
	1	State	○	×	
	2	Instance type	○	×	01H
	3	Transport class trigger	○	×	82H
	4	Produced connection ID	○	×	
	5	Consumed connection ID	○	×	
	6	Initial comm. Characteristics	○	×	01H
	7	Produced connection size	○	×	4
	8	Consumed connection size	○	×	8
	9	Expected packet rate	○	○	
	12	Watchdog time-out action	○	×	00
	13	Produced connection path length	○	×	6
	14	Produced connection path	○	×	20_04_24_01_30_03
	15	Consumed connection path length	○	×	6
16	Consumed connection path	○	×	20_04_24_01_30_03	
17	Production inhibit time	○	×	00	
Services	DeviceNet Services		Parameter Options		
	05H	Reset	none		
	0EH	Get_Attribute_Single	none		
	10H	Set_Attribute_Single	none		

MEMO

Contents

1. Term definition	6-1
2. EDS files	6-2

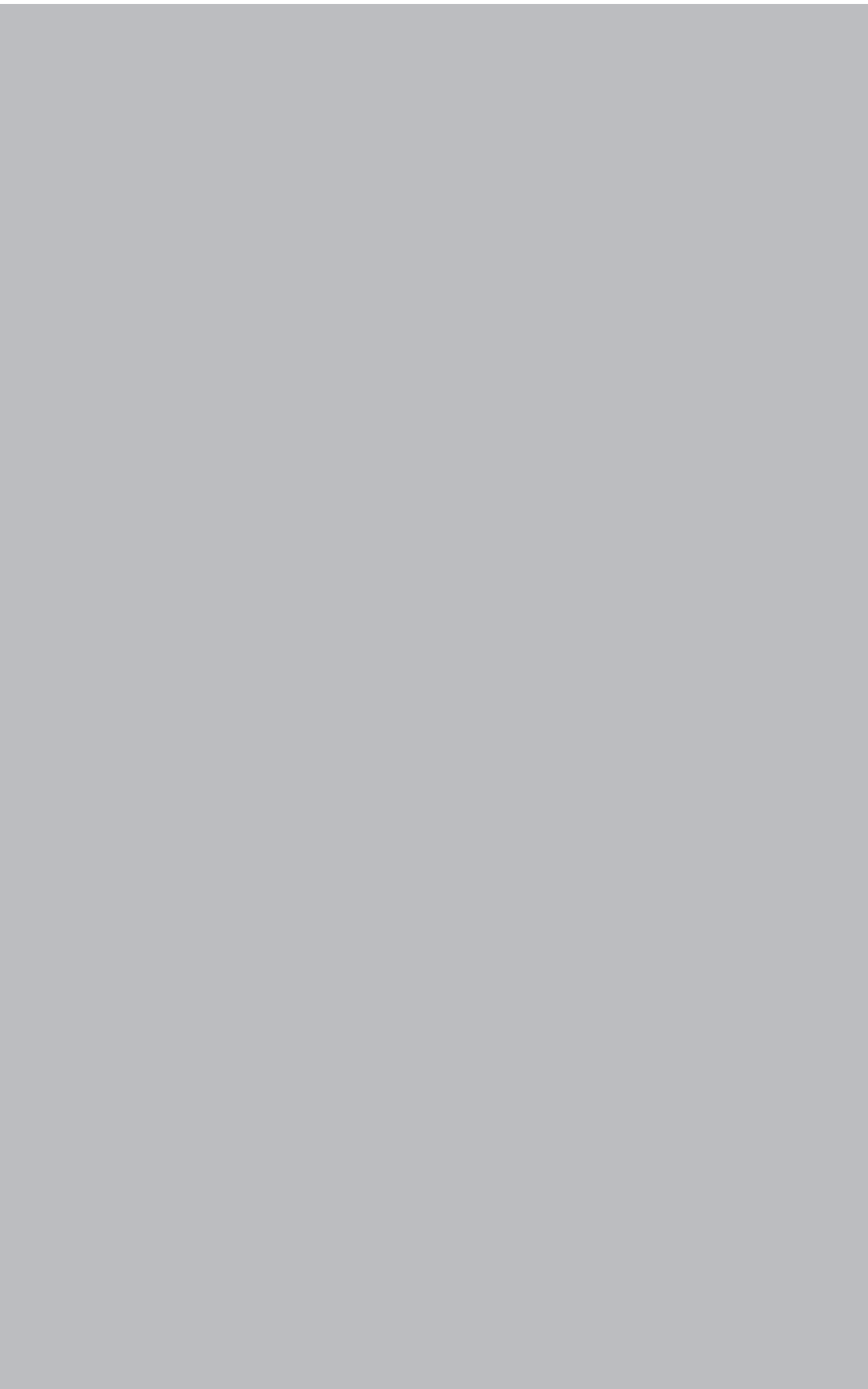

1. Term definition

1. DeviceNet

DeviceNet is a registered trademark of ODVA (Open DeviceNet Vendor Association).

2. SAFE mode setting

When the SAFE mode setting is enabled, service mode input is made valid so that safety functions such as operating speed limits in MANUAL mode can be used. The SAFE mode setting is determined at the time of shipping.

The SAFE mode setting is always enabled for controllers compatible with CE marking.

3. SERVICE mode

This mode is valid only when the SAFE mode setting is enabled, and can be controlled by service mode input signals.

4. SAFETY connector

This connector is used to connect emergency stop input and service mode input. Located on the front panel of the robot controller.

5. STD. DIO connector

This connector is used to receive or output dedicated I/O signals and general-purpose I/O signals. Located on the front panel of the robot controller.

6. MAC ID

Identification number assigned to each node in DeviceNet.
Also called the node address.

7. Bit information

Bit information that can be handled by DeviceNet compatible module.

8. Word information

Word information that can be handled by DeviceNet compatible module.

9. Little endian

Method to substitute LSB in low-order address and refer to LSB when handling word information data as double word data.

For example, when the value 00012345h is substituted in SOD (2), 2345h is substituted in SOW (2) of the first word, and 0001h is substituted in SOW (3) of the second word.

2. EDS files

The contents of an EDS file are shown below just for your reference.

When IO size is "Large"

```

$ DeviceNet Configurator Generated Electronic Data Sheet
$

[File]
  DescText    = "YAMAHA ROBOT EDS File";           $ File Description Text
  CreateDate  = 04-19-2002;                       $ File Creation Date
  CreateTime  = 12:00:00;                          $ File Creation Time
  ModDate     = 04-19-2002;                       $ Last Modification Date
  ModTime     = 12:00:00;                          $ Last Modification Time
  Revision    = 1.1;                               $ EDS Revision

[Device]
  VendCode    = 636;                               $ Vendor ID
  VendName    = "YAMAHA MOTOR CO. LTD.";          $ Vendor Name
  ProdType    = 0;                                 $ Device Type
  ProdTypeStr = "Generic Device";                 $ Device Type String
  ProdCode    = 2;                                 $ Product Code
  MajRev      = 1;                                 $ Major Revision
  MinRev      = 1;                                 $ Minor Revision
  ProdName    = "YAMAHA ROBOT RCX";               $ Product Name
  Catalog     = "";                               $ Catalog Number

[IO_Info]
  Default     = 0x0001;                            $ Default I/O Type Mask

  PollInfo    = 0x0001,                            $ Compatible I/O Type Mask
                1,                                  $ Default Producing Connection
                1;                                  $ Default Consuming Connection

  Input1      = 48,                                $ Size
                0,                                  $ Number of Significant Bits
                0x0001,                             $ Compatible I/O Type Mask
                "",                                  $ Name String
                6,                                  $ Connection Path Size
                "20 04 24 64 30 03",                 $ Connection Path
                "";                                  $ Help String

  Output1     = 48,                                $ Size
                0,                                  $ Number of Significant Bits
                0x0001,                             $ Compatible I/O Type Mask
                "",                                  $ Name String
                6,                                  $ Connection Path Size
                "20 04 24 65 30 03",                 $ Connection Path
                "";                                  $ Help String

```

* EDS files are included on the YAMAHA manual CD-ROM. Use them as needed.

When IO size is "Small"

```

$ DeviceNet Configurator Generated Electronic Data Sheet
$

[File]
  DescText    = "YAMAHA ROBOT EDS File";          $ File Description Text
  CreateDate  = 11-17-2006;                       $ File Creation Date
  CreateTime  = 12:00:00;                          $ File Creation Time
  ModDate     = 11-17-2006;                       $ Last Modification Date
  ModTime     = 12:00:00;                          $ Last Modification Time
  Revision    = 1.0;                               $ EDS Revision

[Device]
  VendCode    = 636;                               $ Vendor ID
  VendName    = "YAMAHA MOTOR CO. LTD.";          $ Vendor Name
  ProdType    = 0;                                 $ Device Type
  ProdTypeStr = "Generic Device";                 $ Device Type String
  ProdCode    = 4;                                 $ Product Code
  MajRev      = 1;                                 $ Major Revision
  MinRev      = 1;                                 $ Minor Revision
  ProdName    = "YAMAHA ROBOT RCX";              $ Product Name
  Catalog     = "";                               $ Catalog Number

[IO_Info]
  Default     = 0x0001;                            $ Default I/O Type Mask

  PollInfo    = 0x0001,                            $ Compatible I/O Type Mask
                1,                                  $ Default Producing Connection
                1;                                  $ Default Consuming Connection

  Input1      = 4,                                  $ Size
                0,                                  $ Number of Significant Bits
                0x0001,                             $ Compatible I/O Type Mask
                "",                                  $ Name String
                6,                                  $ Connection Path Size
                "20 04 24 01 30 03",                $ Connection Path
                "";                                  $ Help String

  Output1     = 4,                                  $ Size
                0,                                  $ Number of Significant Bits
                0x0001,                             $ Compatible I/O Type Mask
                "",                                  $ Name String
                6,                                  $ Connection Path Size
                "20 04 24 01 30 03",                $ Connection Path
                "";                                  $ Help String

```

* EDS files are included on the YAMAHA manual CD-ROM. Use them as needed.

**CAUTION**

IO size setting is only supported by Ver. 8.63 onwards of the RCX14x controllers and Ver. 9.09 onwards of the RCX22x controllers. The IO size for earlier version controllers is the same as the "Large" setting.

Revision record

Manual version	Issue date	Description
Ver. 2.00	Jun. 2007	Addition of function to select the number of occupied channels. Some modifications were made to support RCX22 series (addition of dedicated input/output signal, etc.). Clerical error corrections, etc.
Ver. 2.01	Sep. 2007	Addition of descriptions regarding semi-absolute type axes. Clerical error corrections, etc.
Ver. 2.02	Jul. 2008	Descriptions regarding specifications was changed.
Ver. 2.03	Aug. 2009	Addition of descriptions regarding RCX240 to SI(17), SI(14) in Chapter 5 "1. Profile". Wording of controller name was changed.
Ver. 2.04	May 2011	The description regarding "Warranty" was changed.

User's Manual

YAMAHA RCX series
Robot Controller **DeviceNet**
network board

May 2011

Ver. 2.04

This manual is based on Ver. 2.04 of Japanese manual.

© YAMAHA MOTOR CO., LTD.

IM Operations

All rights reserved. No part of this publication may be reproduced in any form without the permission of YAMAHA MOTOR CO., LTD. Information furnished by YAMAHA in this manual is believed to be reliable. However, no responsibility is assumed for possible inaccuracies or omissions. If you find any part unclear in this manual, please contact YAMAHA or YAMAHA sales representatives.