

# SXYx 2 axes / ZS

- XZ type
- Cable carrier
- Z-axis shaft vertical type

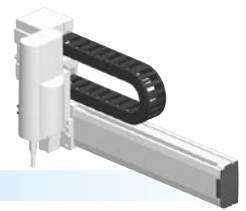

## Ordering method

**SXYx - C** [ ] [ ] [ ] **15** [ ]

Model	Cable	Combination	X-axis stroke	ZR-axis	Z-axis stroke	Cable
F1			15 to 105cm	ZS12		3L: 3.5m
F3				ZS6		5L: 5m
						10L: 10m

**RCX320-2** [ ] [ ] [ ] [ ] [ ] [ ]

Controller / Number of controllable axes    Safety standard    Option A (OP.A)    Option B (OP.B)    Vision System    Absolute battery

Specify various controller setting items. RCX320 ▶ **P.660**

**RCX222** [ ] [ ] [ ] [ ] [ ] [ ]

Controller    Usable for CE    I/O selection 1    I/O selection 2

Specify various controller setting items. RCX222 ▶ **P.670**

## Specification

	X-axis	Z-axis: ZS12	Z-axis: ZS6
Axis construction <sup>Note 1</sup>	F14	-	
AC servo motor output (W)	100	60	
Repeatability <sup>Note 2</sup> (mm)	+/-0.01	+/-0.02	
Drive system	Ball screw φ15	Ball screw φ12	
Ball screw lead <sup>Note 3</sup> (Deceleration ratio) (mm)	20	12	6
Maximum speed <sup>Note 4</sup> (mm/sec)	1200	1000	500
Moving range (mm)	150 to 1050	150	
Robot cable length (m)	Standard: 3.5    Option: 5,10		

- Note 1. Use caution that the flange machining (installation holes, tap holes) differs from single-axis robots.  
 Note 2. Positioning repeatability in one direction.  
 Note 3. Leads not listed in the catalog are also available. Contact us for details.  
 Note 4. When the X-axis stroke is longer than 750mm, resonance of the ball screw may occur depending on the operation conditions (critical speed). In this case, reduce the speed setting on the program by referring to the maximum speeds shown in the table below.

## Maximum payload (kg)

Y stroke (mm)	ZS12	ZS6
150 to 1050	3	5

## Controller

Controller	Operation method
RCX320	Programming / I/O point trace / Remote command / Operation using RS-232C communication
RCX222	

## SXYx 2 axes / ZS (F1)

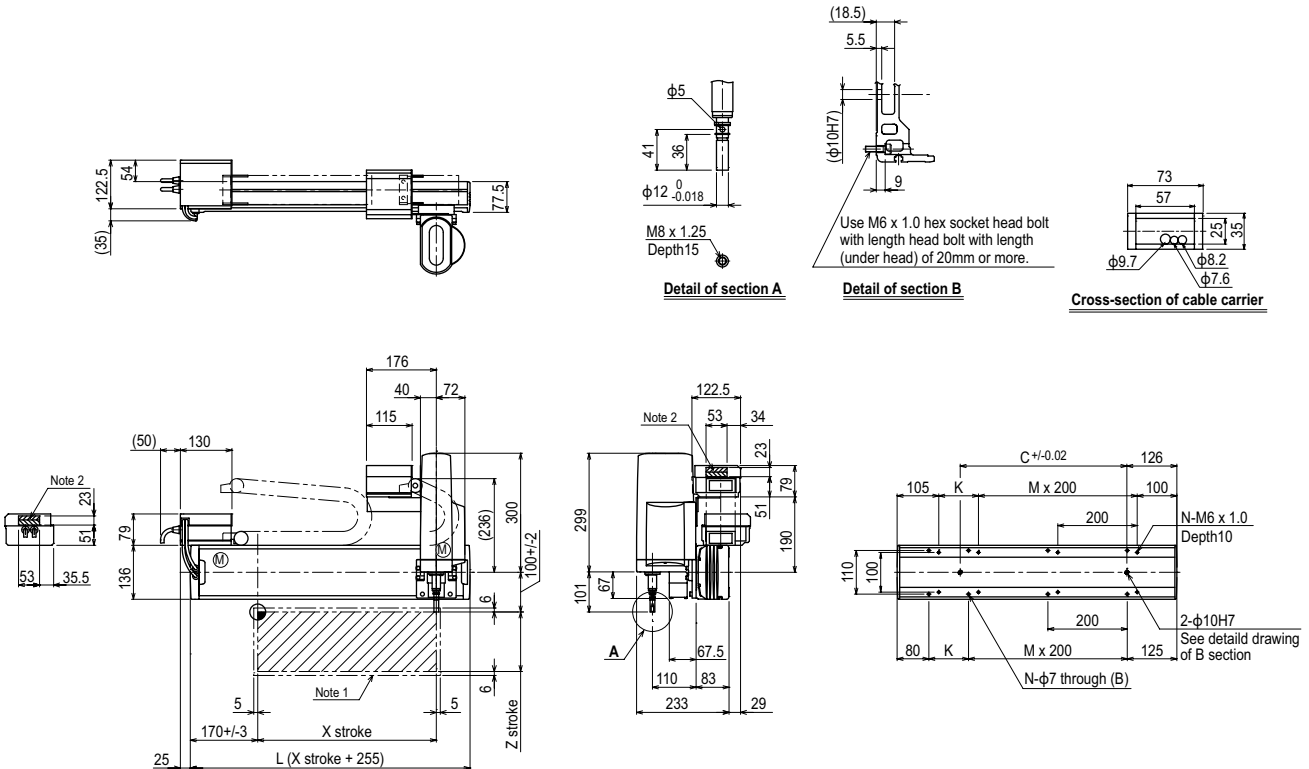

X stroke	150	250	350	450	550	650	750	850	950	1050				
L	405	505	605	705	805	905	1005	1105	1205	1305				
K	200	100	200	100	200	100	200	100	200	100				
C	240	240	420	420	600	600	780	780	960	960				
M	0	1	1	2	2	3	3	4	4	5				
N	4	6	6	8	8	10	10	12	12	14				
Z stroke	150													
Maximum speed for each stroke (mm/sec) <sup>Note 3</sup>	X-axis		1200				960		780		600		540	
Speed setting			-				80%		65%		50%		45%	

- Note 1. The moving range when returning to origin and the stop position when stopping by the mechanical stopper.  
 Note 2. The shaded position indicates an user cable extraction port.

- Note 3. When the X-axis stroke is longer than 750mm, resonance of the ball screw may occur depending on the operation conditions (critical speed). In this case, reduce the speed setting on the program by referring to the maximum speeds shown in the table at the left.

- Articulated robots YA
- Linear conveyor modules LCM
- Single-axis robots CX
- Motor-less single axis actuator Robomity
- Compact single-axis robots TRANSEVO
- Single-axis robots FLIP-X
- Linear motor single-axis robots PHASER
- Cartesian robots XY-X
- SCARA robots YK-X
- Pick & place robots YP-X
- CLEAN
- CONTROLLER INFORMATION
- Arm type
- Gantry type
- Moving arm type
- Pole type
- XZ type